

WaterSpace  
Design Guidance

# Protecting bats in waterside development

June 2018

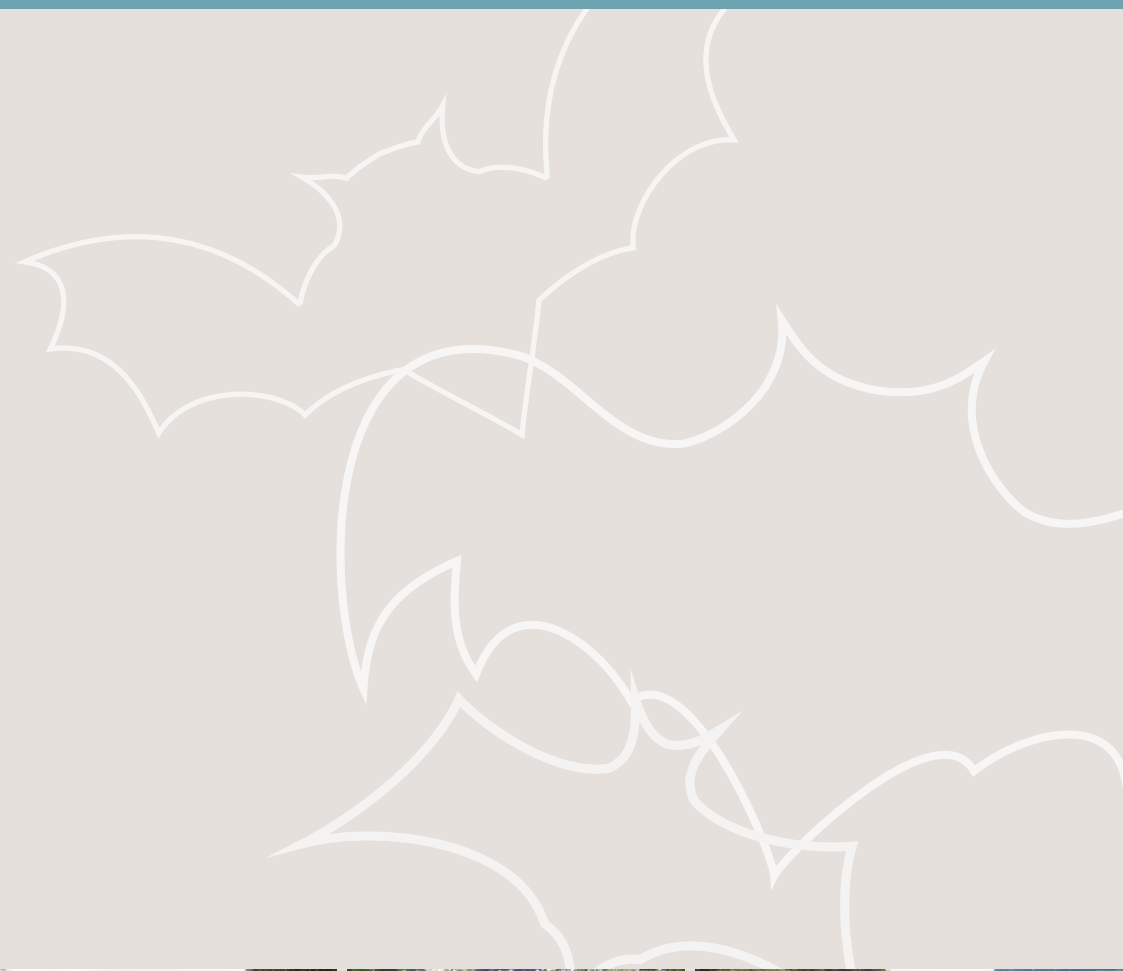

This Guidance was produced by the Planning Department's Environment & Design team, working with ecologists from Clarkson & Woods and Natural England, light engineering specialists from SDS Engineering and Illume Design and landscape architects from Potterton Associates Ltd. Technical support has also been provided from Canal & River Trust's ecology team.



This document can also be viewed via our website:

**[www.waterspacebath.org.uk](http://www.waterspacebath.org.uk)**

This document can be made available in a range of languages, large print, Braille, on tape, electronic and accessible formats by contacting the Planning Department on:

Email:

**[environment&design@bathnes.gov.uk](mailto:environment&design@bathnes.gov.uk)**

The Environment and Design Team

is a multi-disciplinary team of Natural Environment and Design specialists within Bath & North East Somerset Council. The Environment & Design Team are the Council's lead advisors on the following areas: Waterways; Biodiversity; Trees & Woodlands; Green Infrastructure & the River; Landscape and World Heritage site setting; Historic landscapes & gardens; Urban Design; Public Realm and Sustainable Construction.

# Contents

<b>1 Introduction</b>		<b>Bibliography</b>	p33
1.1 Status of the Guidance	p5	<b>Appendices</b>	
1.2 Why guidance is needed?	p5	Appendix 1: River Avon Horseshoe Bat Monitoring Study (2016)	
1.3 Area to which the design guidance applies	p7	Appendix 2: River Avon Horseshoe Bat Monitoring Study Winter Addendum Report (2016)	
1.4 Sites of Nature Conservation Interest on the River and Canal	p8	Appendix 3: Baseline Lighting Survey Data: River Avon – Bath Enterprise Zone (2017)	
1.5 Summary of key evidence	p9	Appendix 4: River Avon Edge Conditions Mapping (2017):	
1.6 Understanding the impact of development on bats	p12		
<b>2 Design Guidance</b>			
2.1 What the guidance covers	p15		
2.2 River Corridor Lighting Zones	p16		
2.3 Design process for waterside developments	p19		
2.4 Information needed to support waterside proposals	p21		
2.5 Design solutions	p25		
2.6 Managing unavoidable impacts	p29		

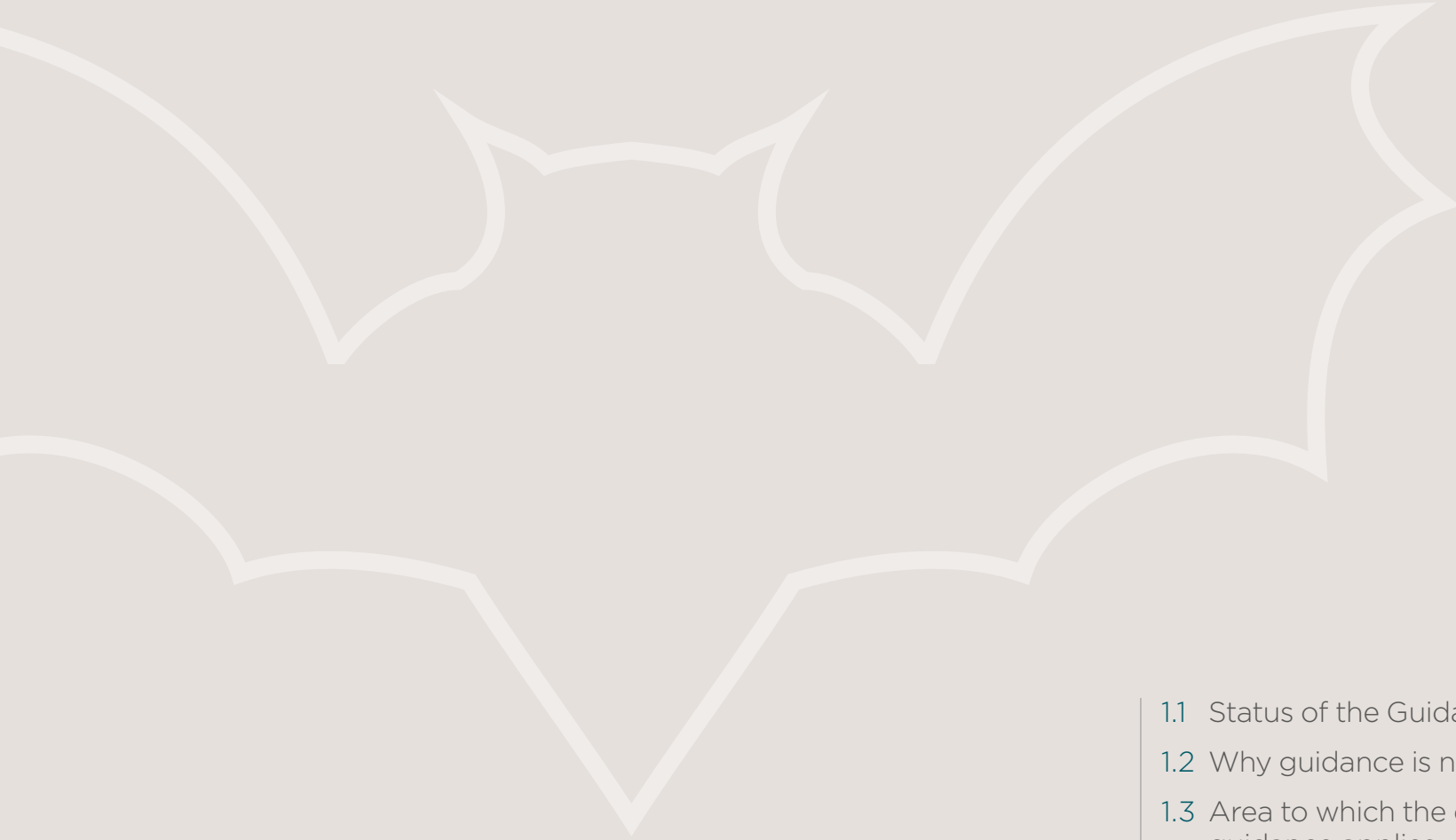

# 1 Introduction

- 1.1 Status of the Guidance
- 1.2 Why guidance is needed?
- 1.3 Area to which the design guidance applies
- 1.4 Sites of Nature Conservation Interest on the River and Canal
- 1.5 Summary of key evidence
- 1.6 Understanding the impact of development on bats

## 1.1 Status of the Guidance

This document provides guidance for use by developers and the Planning Department when dealing with planning applications in close proximity to the River Avon and Kennet and Avon Canal (as shown on Figure 2). These waterways are recognised as providing supporting habitat for the Bath and Bradford on Avon Bat SAC to which the Habitat and Conservation Regulations (Habitat Regs) apply.

The guidance is of particular relevance for development within Bath's Enterprise Zone (as shown in Figure 3) which is centred on the river corridor. The principles will also be relevant where development impacts on other habitat features considered to be supporting habitat for the Bat Special Areas of Conservation (Bat SACs) across B&NES.

It is anticipated that developments that comply with the guidelines would be unlikely to result in a significant effect on Bat SACs within

B&NES, and so would comply with the Habitat Regs.

The guidance supports Placemaking Plan Policies D8: Lighting and NE3: Sites, Species and Habitats.

### Ambition

It is the overarching ambition of this document to safeguard the Bath and Bradford on Avon Bat SAC through good design and decision making.

Specifically, document aims to:

- Help preserve in perpetuity the value of the River Avon and Kennet & Avon Canal in Bath as supporting habitat for the Bath & Bradford-on-Avon Bats Special Area of Conservation (SAC) by maintaining a continuous dark and vegetated river corridor.
- To safeguard other habitat features that support the SAC
- Provide clear consistent advice in order to achieve high quality, ecologically sensitive design for waterside development.
- Streamline and standardise the bat and lighting information needed to support waterside planning applications, and so expedite the planning process in relation to bats & lighting.

### Key Principle

Bats and lighting must be thoroughly considered as part of the planning process. Use of this guidance will be a key requirement within all new waterside development proposals.

The principles will also be relevant for other habitat features considered to be supporting habitat for the Bat Special Areas of Conservation.

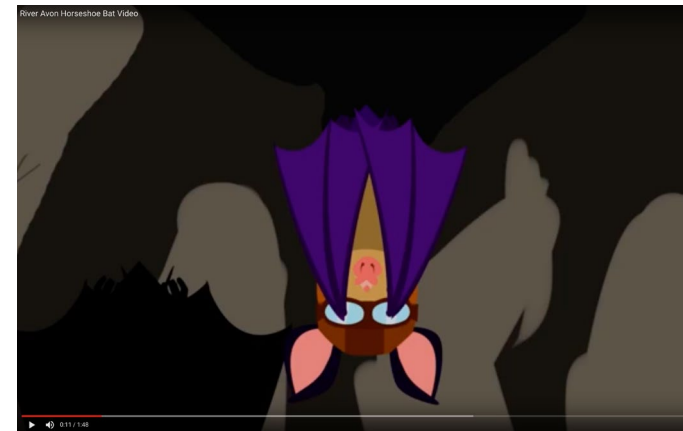

**Figure 1** Animation to show the day in the life of a Horseshoe Bat on the River Avon in Bath, created for B&NES Council for Festival of Nature 2016-17.

## 1.2 Why guidance is needed?

The Bath and Bradford on Avon Bat SAC is served by supporting habitat that lies outside of the formal SAC designation and which can be vulnerable to unmitigated impacts of artificial lighting habitat loss.

Various studies have indicated that the river and canal corridor through Bath provides SAC supporting habitat and is used by many different bat species. Extensive surveys within the BEZ in particular show the river through Bath to be exceptionally important, supporting 12 out of the 18 UK bat species- including the nationally rare lesser and greater horseshoe bats associated with the SAC. This bat interest within the BEZ is exceptional given the urban context.

These studies also confirm that the river corridor is used by bats throughout the year in different ways. Horseshoe bat use is particularly interesting. Notably, these bats navigate along the river corridor their highest numbers in the autumn and spring, times associated with peak migration movements to and from the hibernation sites of the SAC. Significantly, the research shows continued use of the river corridor by bats, including horseshoe bats, during every month of the year.

These findings confirm the importance the river corridor. As a result the corridor is recognised as providing supporting habitat for the SAC and so requires statutory protection under the Conservation of Habitats and Species Regulations 2017.

It is the Local Planning Authority and Natural England's position that these interests must be protected and where possible enhanced. Provision for continued use of the river by horseshoe and other bat species is therefore a basic requirement for all new development and landuse management close to the river

The bat interest of the City and its river is something to celebrate and cherish. It is part of why Bath is special, exciting and unique. It also brings challenges - particularly for new waterside development as bats have complex habitat requirements, and all species and their roosts, and supporting SAC habitat, are legally protected.

Protecting bats and their roosts is a routine planning and legal requirement. Comprehensive guidance is readily available for the bat activity surveys and site assessments required for planning applications where direct impact upon bats and their roost are likely (see Bat Surveys for Professional Ecologists: Good Practice Guidelines, 3rd ed. 2012, Bat Conservation Trust).

Additional guidance in the form of this document is needed for waterside developments where the indirect impacts of lighting and habitat removal from new development or land management, could be a significant risk to bat conservation. Potentially this could affect the integrity of the SAC, and so can cause significant delays and additional costs within the planning process. The guidance is needed to help clarify and facilitate the planning process in terms of bats and lighting in particular for sensitive waterside development.

The approach will also be relevant where development and/or land management change will affect other SAC supporting habitat features assessed as having at least regional importance for bats.

### Who is this guidance for?

This guidance is for developers, consultants, planners, land managers and others involved with planning and land management.

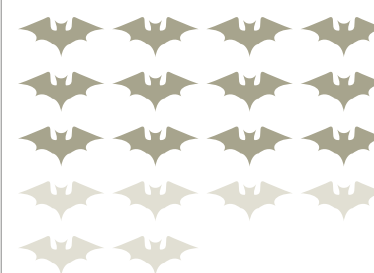

# 12

of 18 UK bat species can be found on the River Avon corridor in Bath

## 1.3 Area to which the design guidance applies

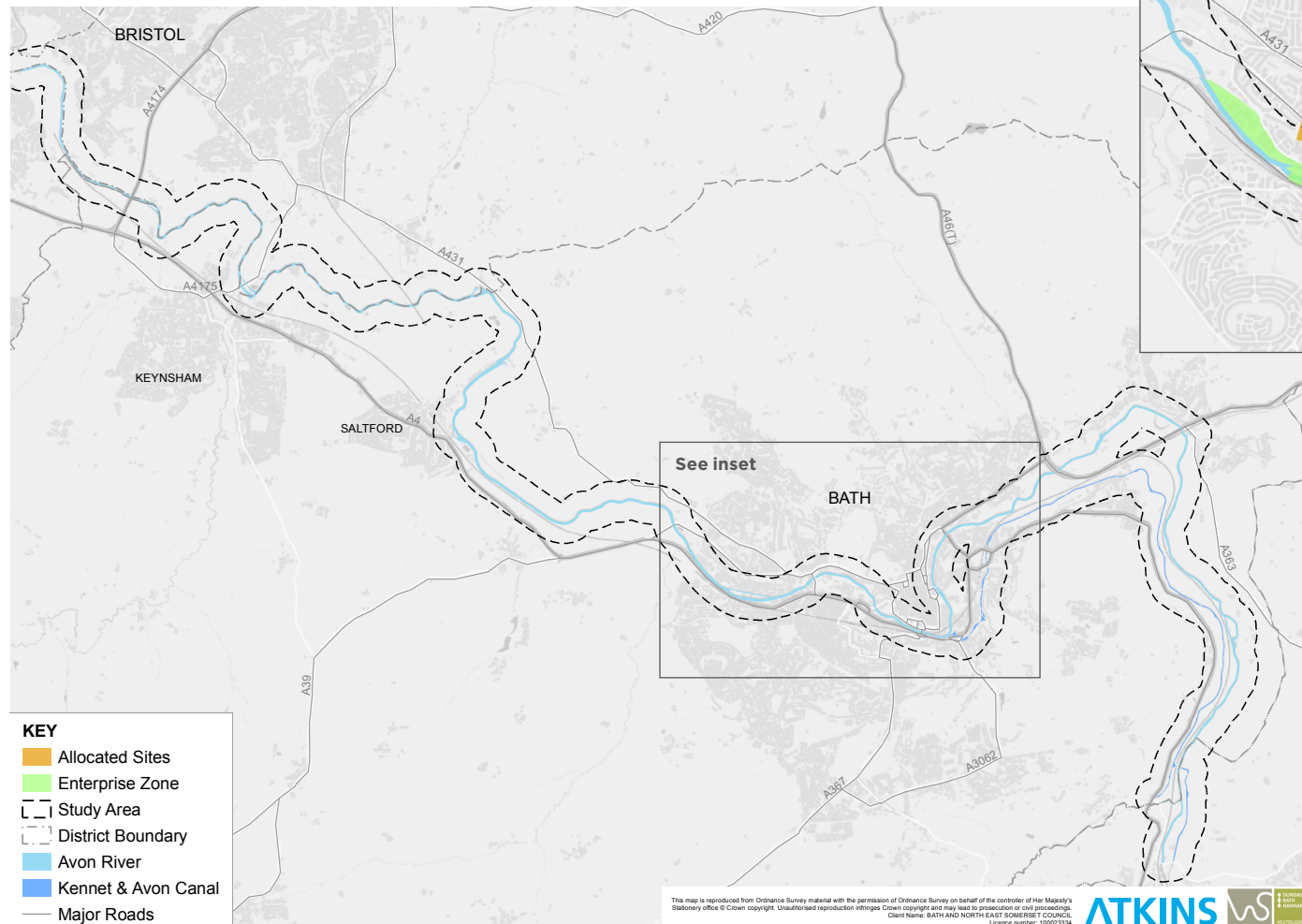

**Figure 2** WaterSpace Area to which the guidance generally applies



**Figure 3** Bath's Enterprise Zone to which the guidance specifically applies

This guidance generally applies to all waterside development areas within Bath, Keynsham, Salford and surrounds within the WaterSpace project area (as shown in Figure 2). The principles will also be relevant in other situations where Bat SAC supporting habitat is confirmed.

It specifically applies to the River Avon corridor within Bath's Enterprise Area – 98 hectares of land on or close to the banks of the River Avon, which is focus for regeneration and development.

The Enterprise Zone in Bath has been the focus of extensive bat surveys and research (as shown in Figure 3).

## 1.4 Sites of Nature Conservation Interest on the River and Canal

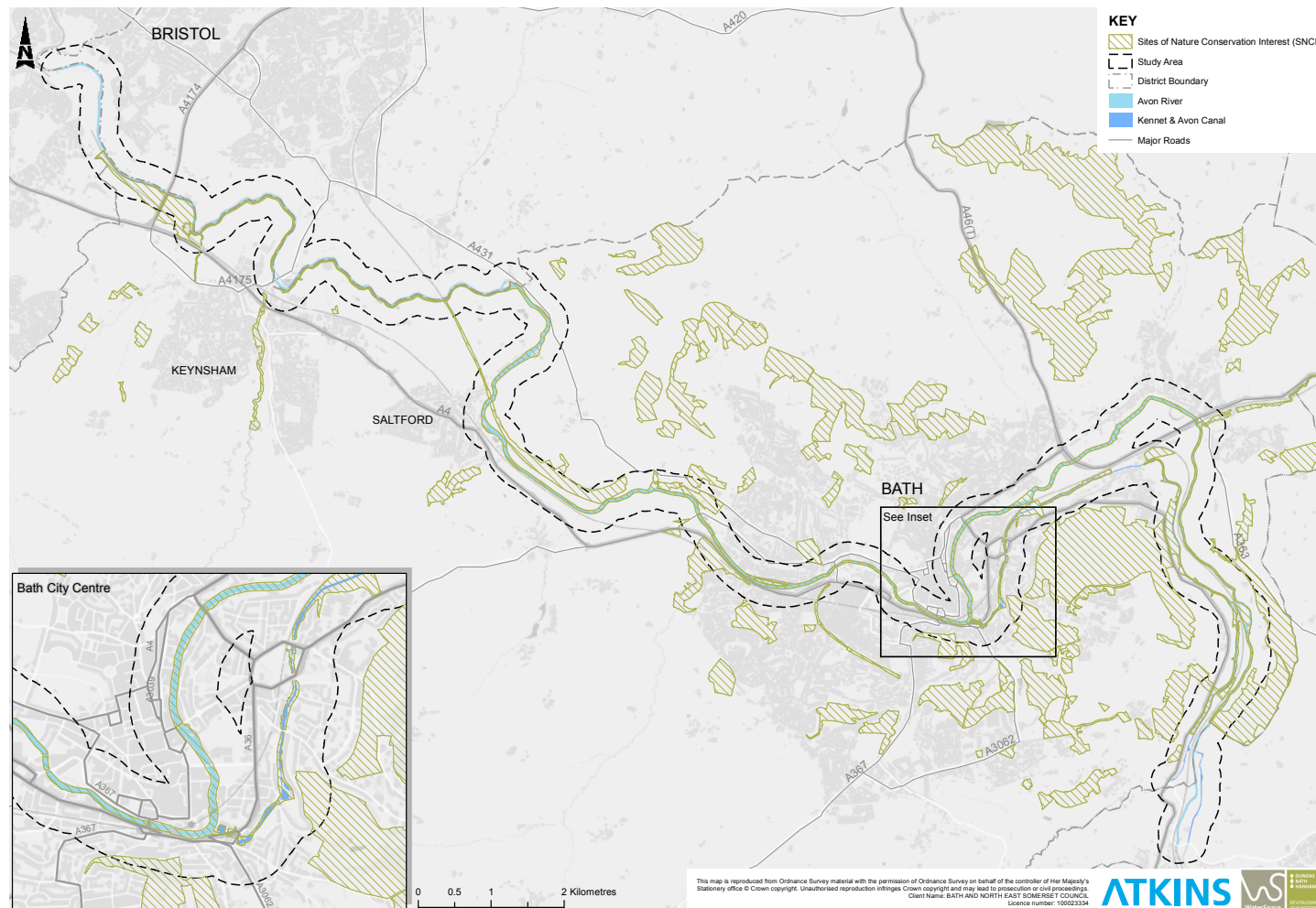

**Figure 4** Map of Sites of Nature Conservation Interest (Bath & North East Somerset Local Plan, 2017)

Both the River Avon and the Kennet and Avon Canal corridors are designated as Sites of Nature Conservation Interest (SNCI), in the B&NES Local Plan and have protection for their ecological value.

The Kennet & Avon Canal SNCI (area 29 hectares) is designated on the basis of its standing water and associated marginal habitats, semi-natural broadleaved woodland, semi-improved neutral grassland and tall ruderal communities.

The River Avon SNCI (area 127 hectares) is designated on the basis of its running water and associated marginal habitats.

Both waterways have a critical role for bat species, including the rare Horseshoe bats (greater and lesser). The dark and well vegetated and natural banksides and green tunnelling on towpaths in particular provide good foraging habitats and movement corridors from roosts out to the wider countryside and key foraging habitats.

The River Avon corridor through Bath is identified as a Strategic Green Infrastructure Corridor in both the Green Infrastructure Strategy and the Local Plan. A number of other SNCI link into the river and canal corridors, as shown in Figure 4.



## 1.5 Summary of bat survey evidence

### Bat Surveys

During 2016-17, 12 months of bat surveys were undertaken to investigate the value of the urban section of the River Avon through the Bath Enterprise Area for bats, with a particular emphasis on lesser and greater horseshoe bats.

The surveys were undertaken in two parts:

- Summer Survey (April – October 2016)
- Winter Survey (November 2016 – March 2017)

The summer survey included both static bat detector surveys in 10 bankside locations as well as walked transects. The data collection was accompanied by a rapid assessment of vegetation cover and night time illumination of the bankside.

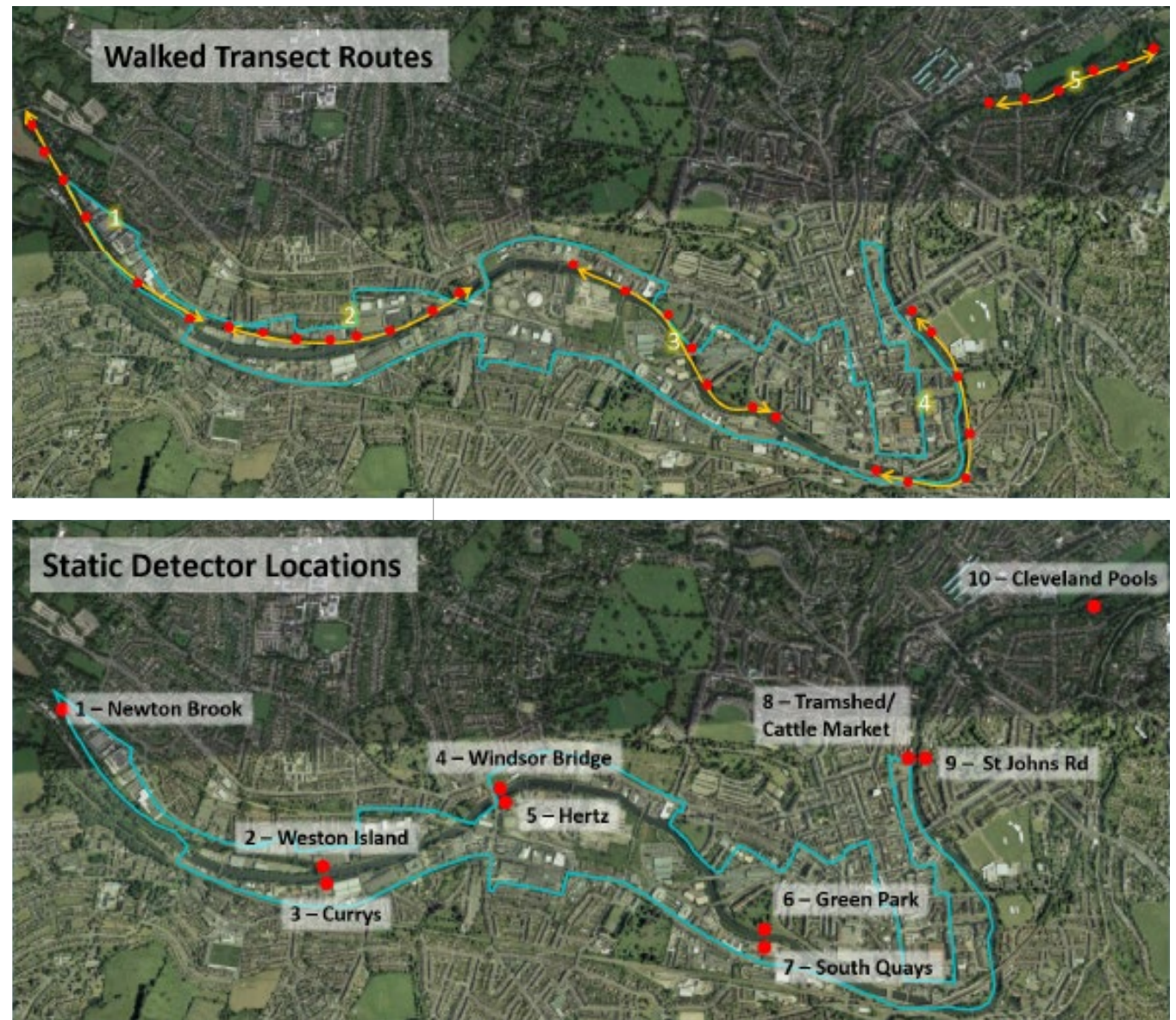

**Figure 5** Summer Bat Survey Locations (2016-17)



**Figure 6** Survey locations and findings in terms of Horseshoe bat passes (Summer 2017 survey).



**Figure 7** Example community bat survey for the River Avon at Newbridge, Festival of Nature 2016.

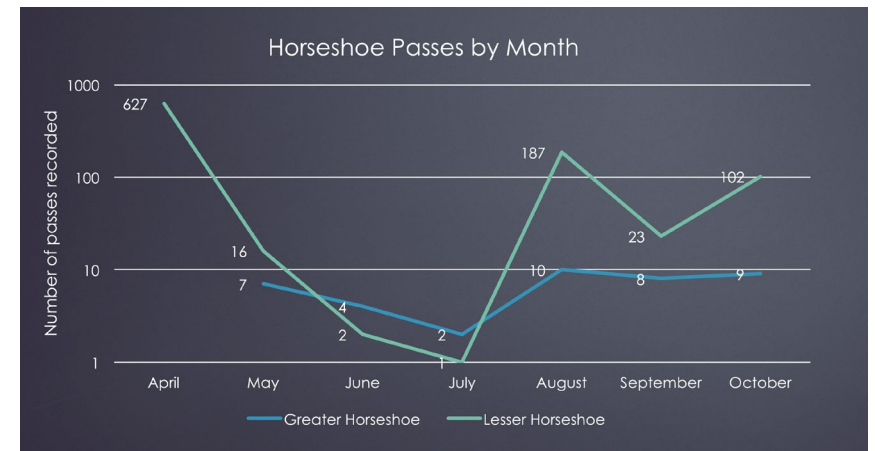

**Figure 8** Summer Survey Data of Horseshoe bat passes per month.



Populations associated with the Bath and Bradford on Avon Bats Special Area of Conservation (SAC) are utilising the River Avon corridor in Bath. The river corridor and banks, and associated habitat must therefore be considered supporting habitat for the SAC.

12 out of 18 UK bat species were recorded in both survey periods, including exceptionally high activity rates from common pipistrelle, soprano pipistrelle, barbastelle and nathusius and daubenton.

Furthermore, it is noted that bat activity was found during both winter and summer, therefore, recommendations relating to the avoidance of lighting on the river as part of new development proposals, should be applicable year-round. It was previously thought that part-night lighting or automated dimming would only be necessary during the summer months, however, we now know is not the case.

#### Summer Survey Headline Findings:

- Lesser Horseshoe bats were recorded in the river corridor every month, and at every static detector locations, and 3/5 walked transect locations. This activity was focused at the eastern and western locations.

- During the spring and autumn months there was more Horseshoe bat activity, highlighting the value of the river corridor as a transition between winter hibernation and summer breeding roosts.

- Horseshoe bat activity was largely made up of commuting/dispersal behaviour according to a time-of-night analysis, although a significant amount of foraging activity was also recorded.

- Horseshoe bat activity was greatest at locations where *ambient light levels were lowest and where vegetation was densest*, particularly where a 'green lane' effect was formed. Hard-edged banks were generally less favoured, although activity persisted where there was a dark 'shadow' zone afforded by a tall hard-edged bank to screen illumination, even in the absence of vegetation.

- Horseshoe bats were most often observed *flying within 2m above the water's surface and between 5m either side of the water's edge*, flying closer to the bank where bankside vegetation coverage was lowest.

- This indicates that the bankside is *the most important feature of the river for horseshoe bats*, probably as these species tend to require strong linear features for navigation through the landscape.

- Light levels were observed to be a greater predictor of horseshoe activity rates, with vegetation cover also a factor.

#### Winter Survey Headline Findings:

- The surveys recorded lesser horseshoe bats within the river corridor during every month, particularly around known and suspected winter roosts in the west and east.

- Lesser horseshoe bats were recorded during every month with activity increasing in March (where they were recorded at every static detection site)

- Greater horseshoe bats were recorded in three locations and only in November and December, being later to emerge from hibernation.

- Horseshoe bats showed a tendency towards activity in the period shortly after sunset and shortly before dawn.

- This was the first time winter bat activity has been confirmed Bath Enterprise Zone.

#### Light Level Data

During summer 2017, night and day light surveys were undertaken at 79 locations within the Bath Enterprise Zone, point illuminance was measured in 4 directions for each location.

This data highlights the base lighting conditions, it can be noted that there are areas of significant light spill, and other sections that are very dark. The impact of lighting from one river bank to the other was also noted.

#### Other Mapping

As part of the WaterSpace Study the edge conditions for the River Avon have been mapped – e.g. natural bank, sheet piling etc.

✚ The Full Reports mentioned can be found in Appendices 1-4.

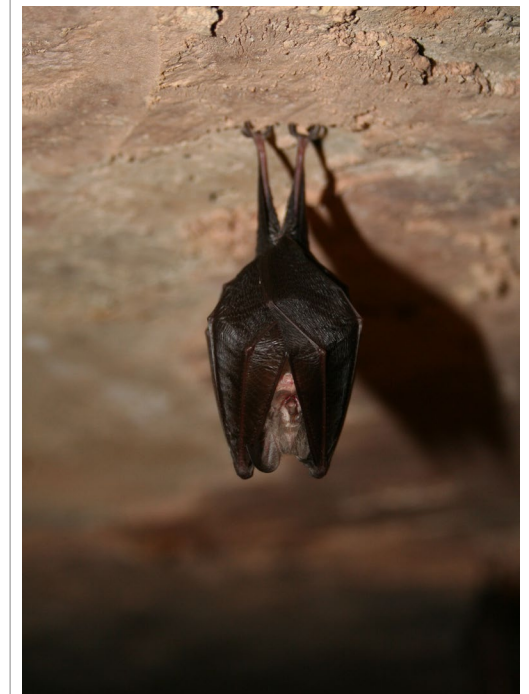

## 1.6 Understanding the impact of development on bats

Bats are nocturnal, mobile species which make use of different roost sites and food sources during the course of a single night and across the course of a year. They feed on different insect prey as different food sources become available at different locations and so need access to a range of vegetation and natural habitats. They use the cover of darkness to minimise the risk of predation and so need safe access to and from their varied roost sites and feeding areas. Safe access means naturally dark flight-lines and foraging habitat where the risk of predation is minimised.

Preferred feeding areas will typically be structurally diverse habitats that support a varied insect fauna (woodland edges; tree lines; hedgerows, pasture, verges, river banks etc.). Whilst a small number of species will feed under street lights, natural darkness - free from artificial light - is typically key to bats' survival

and population vitality. Their food sources are affected by light. Furthermore, many species rely on unlit linear features for navigation. Horseshoe bats are especially light sensitive, preferring to forage in very dark conditions.<sup>1</sup>

This is particularly important at the hours immediately following dusk and pre-dawn when bats will be most active.

The integrity of the river corridor and its suitability for bats, in particular the horseshoe bats associated with the SAC, is threatened by two key factors associated with development and landuse management:

- 1) The increase in night-time illumination of the river and its bankside habitats from new internal and external light sources
- 2) The removal or change in bankside habitat structure and extent, removing key linear dispersal features and foraging habitats.

<sup>1</sup> Stone, E. L., Jones, G. & Harris, S. (2012) Conserving energy at a cost to biodiversity? Impacts of LED lighting on bats. *Global Change Biology* 18:8, pp.2458-2465.

The main impacts of increased artificial illumination including light spill are:

- Barrier effects - leading to increased energy expenditure finding new routes or the degradation and

abandonments of flightpaths altogether. This may lead to reduced breeding success or increased winter mortality as seasonal movements are impeded.

- Reduced foraging opportunities - increased environmental illumination using certain wavelengths can draw a proportion of invertebrates from unlit areas, thereby reducing food abundance for light-sensitive bats such as horseshoe bats.
- Delayed emergence - bats tend to emerge from roosts within the first 90 minutes after sunset whereupon foraging is typically a priority. Higher environmental light levels in proximity to roost sites have been shown to delay the onset of emergence leading to reduced time available for foraging, reducing overall fitness.



The main impacts of habitat removal or change are:

- Reduced habitat connectivity - impeding seasonal migration and nocturnal navigation.
- Reduced foraging habitat extent - affecting foraging success and overall fitness.
- Reduced screening and light attenuation - tall and/or dense vegetation can provide significant benefits of screening glare and attenuating light

The recent Bath Enterprise Zone bat studies reveal that the dark vegetated areas of the river are preferentially used, and that light shy species typically make use of a zone of up to 2m above the water's surface and between 5m either direction from the water's edge as illustrated in Figures 9 and 10. Therefore the removal of riverside vegetation and introduction of artificial light must be avoided wherever possible or minimised with impacts fully identified and mitigated.

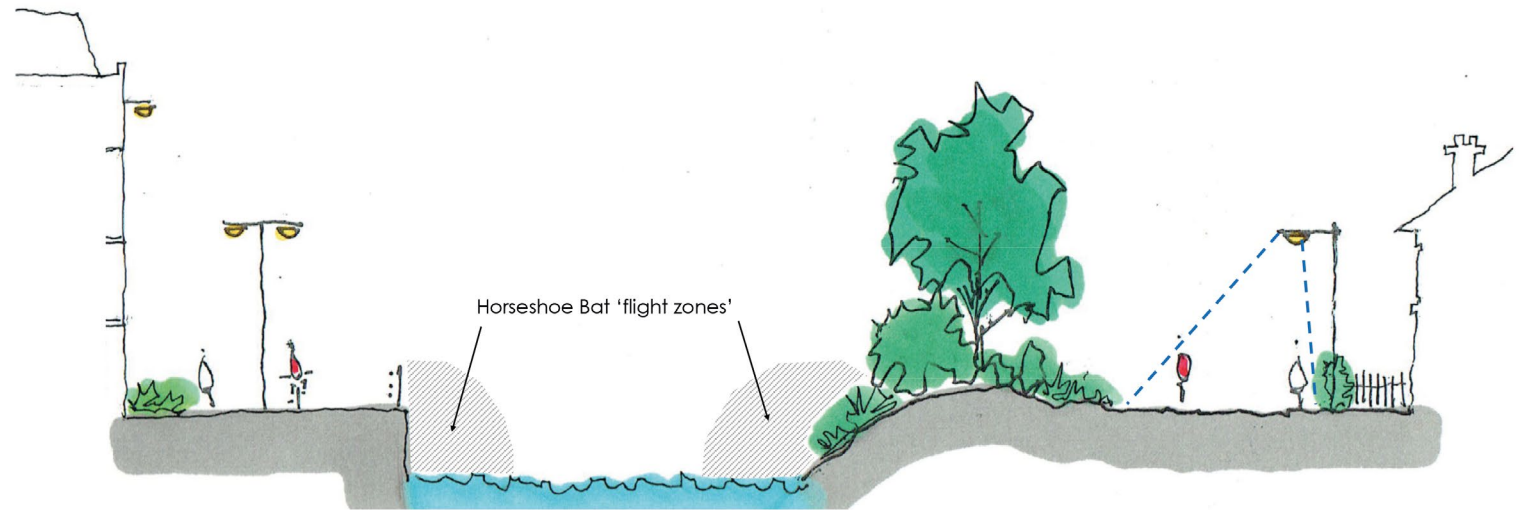

**Figure 9** Horseshoe bat 'flight zones'

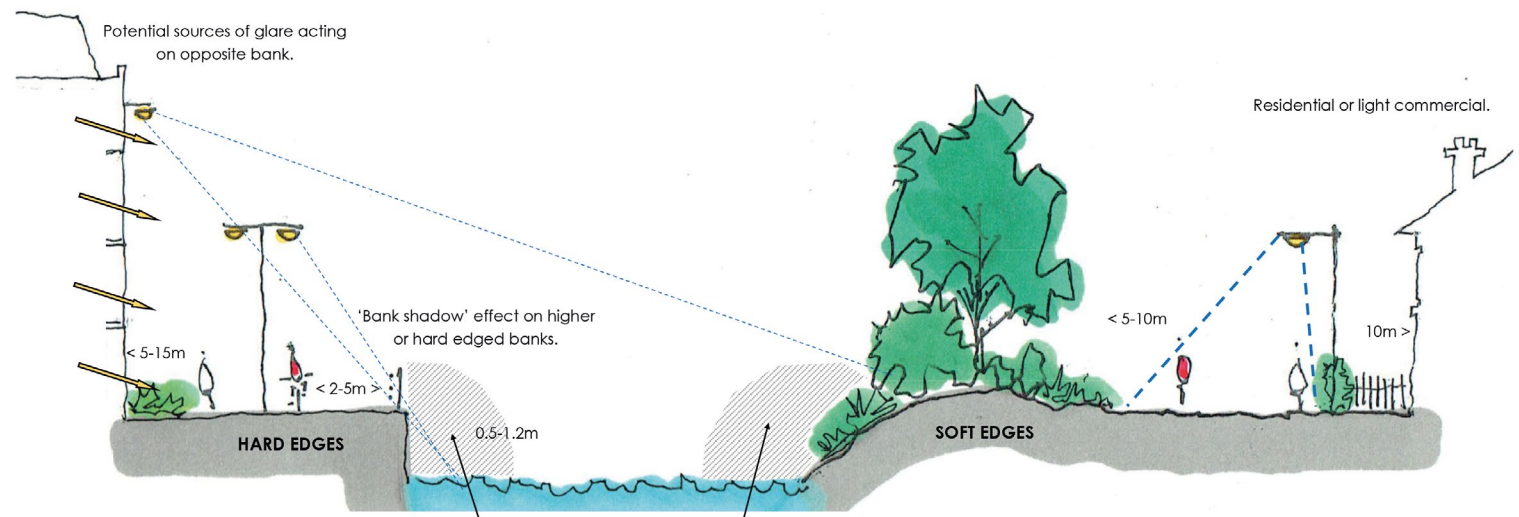

**Figure 10** Indicative section to show location of key Horseshoe bat flight zone area in relation to river bank

# Design Guidance

- 2.1 What the guidance covers
- 2.2 River Corridor Lighting Zones
- 2.3 Design process for waterside developments
- 2.4 Information needed to support waterside proposals
- 2.5 Design solutions
- 2.6 Managing unavoidable impacts



## 2.1 What the guidance covers

Delivering the planned levels of growth for the Bath Enterprise Zone whilst protecting and enhancing bat interests in this way requires a carefully considered approach. This is necessary to achieve good, policy compliant design, but also to minimise survey requirements and avoid costly delays. There are three distinct aspects to this:

- 1) The riverside bats and lighting issue needs to be acknowledged and integrated into the design process from the outset, and in an iterative way. It should not be left to later design stages or be retrofitted into proposals.
- 2) New development must avoid light spill onto the river, the water's edge and banks (thereby observing the key bat flight zone in Figures 9 and 10). Consideration of light spill from buildings (internal sources) and from lighting outside space (external sources), must be demonstrated.
- 3) Development should retain and reconnect existing areas of suitable bat habitat, create new bat-friendly landscaping and provide for its maintenance.

To address these requirements the guidance sets out the following:

- A River Corridor Lighting Zone concept.
- A specific 'bats and lighting' design process.
- The specific information required to support waterside planning applications.
- A suite of design solutions for light spill mitigation that can be adopted to avoid or reduce light spill from new development.

### Light and Light Spill

There are many different terms and measure related to light and light spill.

For this guidance we are concerned with light from light sources provided for specific purposes spilling unnecessarily onto natural habitat of value to bats. Light spill sources of concern will include lighting designed to light external spaces (External light spill), and lighting designed for internal spaces within buildings (Internal light spill). The usual measure of light spill will be lux levels (lx). Lux (Illuminance) is a measurement of the light intensity at any point. The metric unit = lumen/m<sup>2</sup>.

## 2.2 River Corridor Lighting Zones

As the risk of disturbance from light diminishes inland with distance from the water's edge, it is useful to divide development sites into discrete zones oriented parallel to the river according to their sensitivity and intended land use (see Figure 11). These zones can then be used to determine the light spill limits to be imposed at the outset of scheme design.

River corridor lighting zones have been devised to guide development requirements. The lighting limits have been chosen according to current research findings, the current light readings within known dark flight paths in the study area and the need to adopt a precautionary approach.

Table 1 gives a summary of the expectations for land-use, light levels, landscaping design and zonation width as well as lux level limits for each zone.

Maintaining a dark corridor in Zones A and B is the priority, as these accord with the areas of greatest importance to bats.

Zone B may be accessible to pedestrians and other users, for example along the towpath or other rights of way, but zones A and B are primarily zones of natural dark habitat.

Zone C is the transition zone between the focal areas of the development and the river's edge, where the urban environment gives way to softer landscaping and natural features.

Finally, Zone D will contain the bulk of the hard landscaping and built structures.

The width of these zones is not fixed, instead each must be applied according to the end land-use of the scheme taking into account the site's topography, habitats, connectivity and existing development. Typical width ranges according to possible site characteristics are given in Table 1.

The zone widths must be determined appropriately, ideally with the assistance of an ecologist in order to ensure the function of zones A and B as a bat habitat corridor is likely to be achievable. The input of the lighting engineer here can be invaluable as zones A and B are the principal receptors where the lighting scheme will need to avoid impacts.

The limits imposed are for light spill resulting from sources within the application site and adjacent land controlled by the landowner only. This includes lighting from both outdoor (environmental lighting) and indoor sources as well as wall-mounted luminaires.

These requirements will only be met where the principle of lighting as a key design parameter is recognised at the onset of project planning and where an iterative design process is used.

### Lighting of Bridges

Lighting of bridges poses specific challenges and is a major risk to maintenance of a viable dark corridor along the river. If poorly considered bridge lighting could lead to significant light barriers across the river and loss of bat populations. All lightspill onto the water surface should be avoided and the bridge landings must be designed to accord with the guidance and to achieve the lightspill requirements for Lighting Zones A & B.



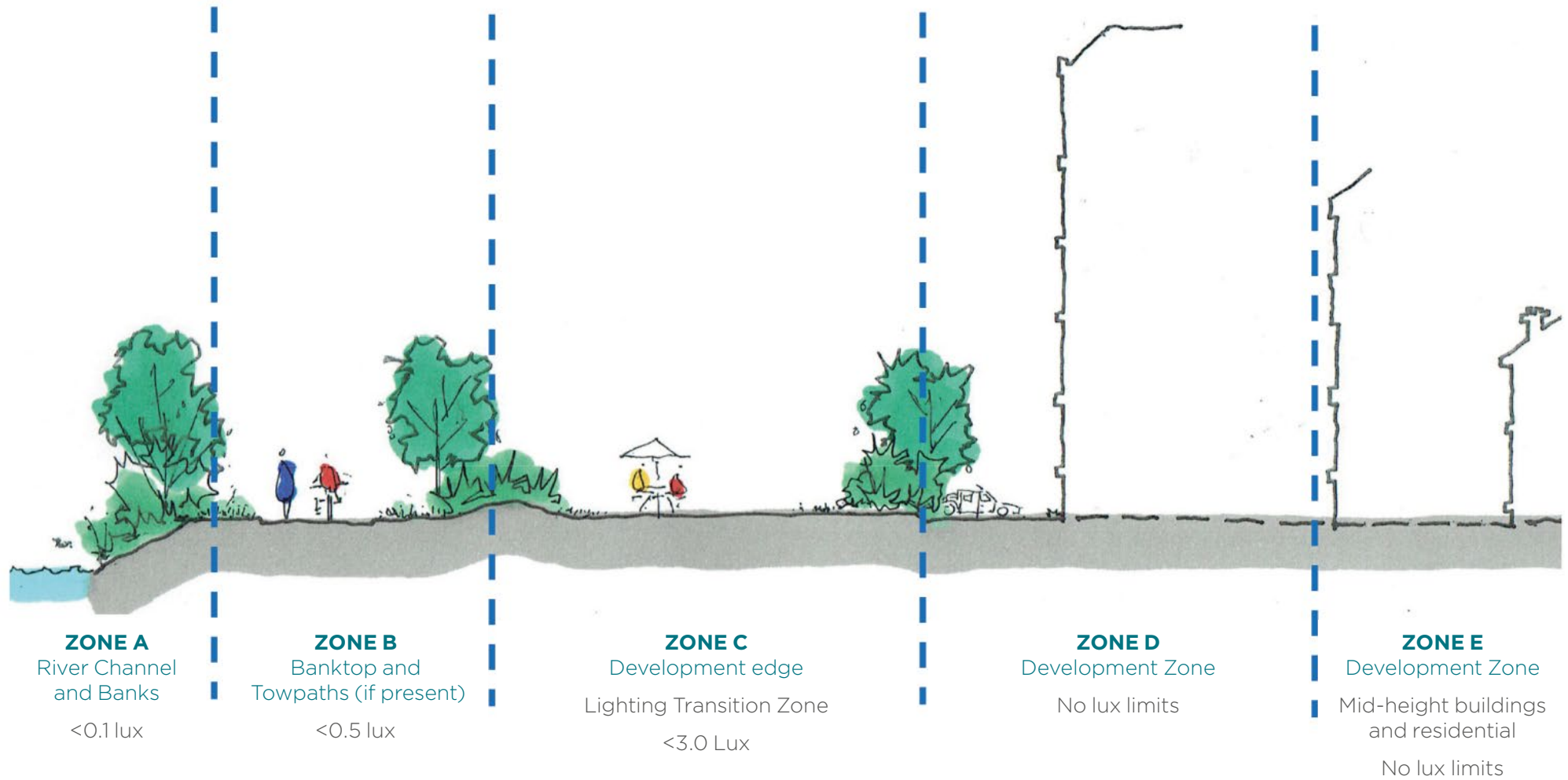

| **Figure 11** Lighting Zones for the River Corridor.

Zone	A (River Channel and Banks)	B (Banktop and Towpath)	C (Lighting Transition Zone)	D (Core Development Zone/ Urban Zone)
<b>Indicative distance from water's edge covered by zone</b>	0 to approx. 2m	Approx. 2m to approx. 6m	Approx. 6m to approx. 10m	
<b>Description</b>	River channel and banksides. Includes natural and engineered banks, moorings etc.  <b>Highest</b> sensitivity zone for bats.	Bank top, which incorporates the towpath on northern bank or riverside walkways elsewhere.  In other locations this may include flat ground with habitat continuation of bank vegetation, although may be more scattered.  <b>Highly</b> sensitive zone for bats.	Transition zone between undisturbed river corridor and built development.  Includes variety of uses and including recreational amenity areas.  NB. May contain linear natural features which run perpendicular to river towards Zone D, i.e. hedgerows/trees/walls.  <b>Moderately</b> sensitive for bats.	Development Zone. Includes illuminated parking and the first buildings in from the water's edge.  Characterised by a dominance of hard standing and built structures.  High human activity. Dominated by roads and buildings.  <b>Low</b> sensitivity for bats.
<b>Lighting</b>	<b>Lux contours from development &lt;0.1 lux.</b>  <b>Must remain unlit with no glare impact from development.</b>	<b>Lux contours from development &lt;0.5 lux.</b>  <b>Must remain unlit with no glare impact from development.</b>	<b>Lux contours from development &lt;3.0 lux.</b>  Lighting scheme to incorporate innovative lighting solutions – e.g. bollards, cowls, automation, recessed bulbs, walls/screens, smart glazing.	<b>No lux limits.</b>  Restrict potential sources of glare from acting upon Zones A-B (e.g. exterior security/flood lighting, light spill from windows) through sensitive lighting design. Building elevations fronting Zones A-B to receive particular focus.
<b>Development</b>	No development typically permitted.  Natural habitat and structure to be retained wherever possible.  No/limited human access.	No development, although permeable access for cyclists and pedestrians.  Fencing may be appropriate.  Habitat to be retained and/or reinstated.	Limited development, mostly comprising communal amenity areas, fencing and landscaping or unlit services buildings.	Buildings and hardstanding dominant.
<b>Landscaping</b>	Green infrastructure planting actively encouraged to increase value for bats.  Maintenance access only. Fencing may be appropriate	Green infrastructure planting actively encouraged to increase value for bats.  Opportunities for light attenuation through soft landscaping in this zone.	Potential for appropriate landscaping and planting of benefit to bats.  Landscaping (soft and hard) can be used to screen the river corridor from unintended light spill and activity associated with the development.	Hard landscaping and buildings dominant.

**Table 1** Lighting Zones for the River Avon Corridor

## 2.3 Design process

To enable this guidance to be applied a specific design process is proposed as illustrated in Figure 12. This process ensures that any constraints posed by bats and lighting can be identified at an early stage, appropriate professional advice can be sought, and potential conflicts can be avoided.

### Basic Steps

- 1) Ensure the design team is fully aware at the onset that lighting and bats could be significant issues for any development or land management project within 30m of the river edge.
- 2) Light-spill generated from both external and internal lighting designs will need to be considered. In line with the principles outlined in Table 1 and Figure 11.
- 3) The design team should have a clear understanding of the site's baseline habitat conditions.
- 4) The River Corridor Lighting zones should be applied to determine the site's light spill requirements and these must be shared with the design team.
- 5) A light mitigation scoping exercise should be undertaken and relevant effective mitigation measures should be embedded in the scheme design.



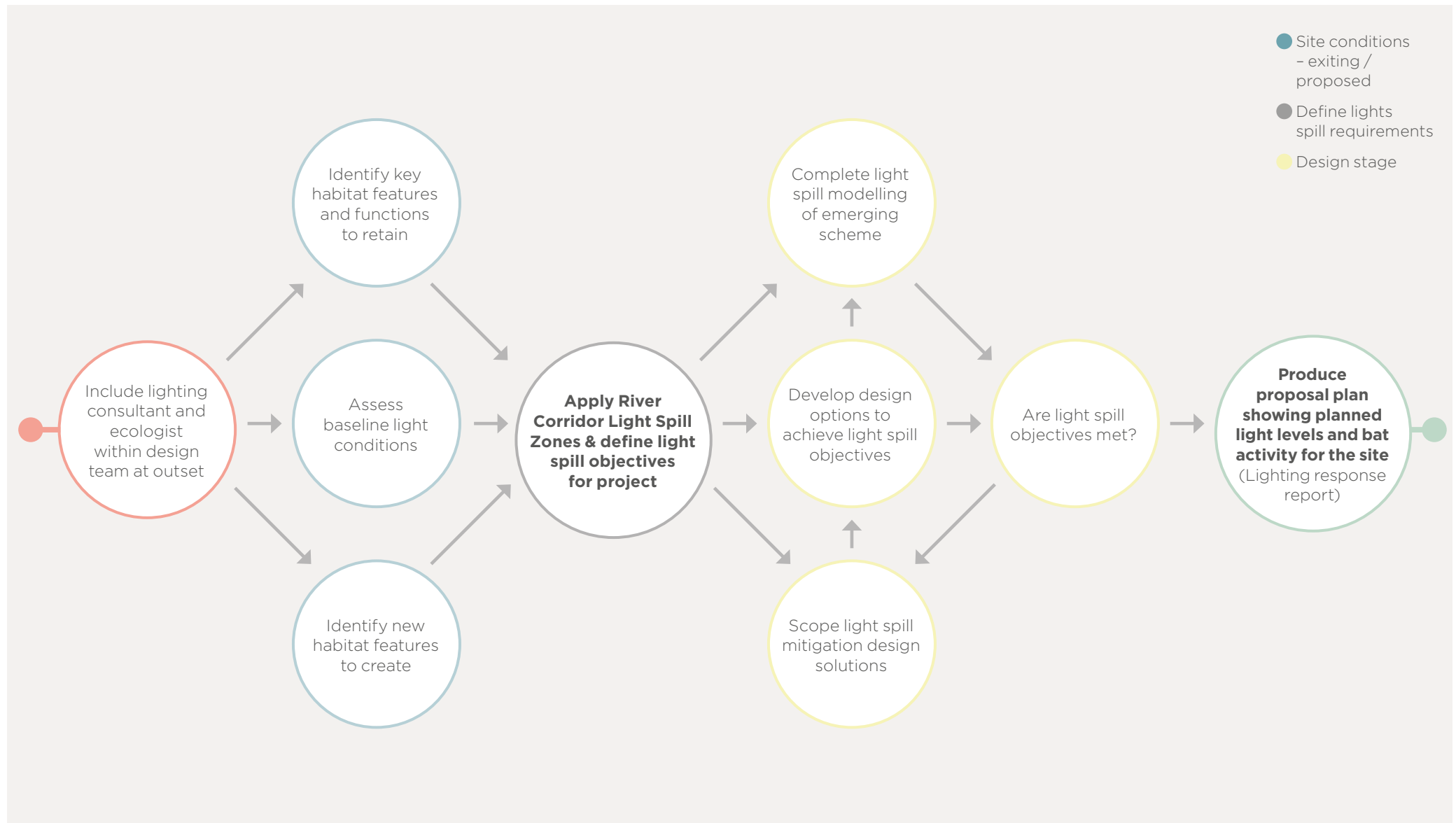

**Figure 12** Design process for bats and development within 30m of River

## 2.4 Information needed to support waterside proposals

In many situations bats will not be the only ecological constraint and so there will be cross-over here with wider ecological issues and planning requirements. It is recommended that the information listed here is submitted as a **Bats & Lighting Response Report**, either as a standalone report or as part of the scheme's wider ecological report.

This information should be provided concisely and where possible using annotated maps, lux contour plans (isolux plots) and site plans to avoid lengthy documentation. Please note that, where interior or exterior lighting is to be installed in or in proximity to Zones A - C, lux contour plans, isolux diagrams or similar graphic representations of illuminance levels showing light spill on vertical plans are likely to be required, and should be produced by a competent lighting professional as set out below.

The Bats & Lighting Response Report may need to be completed as a collaboration between ecologists, lighting professional, landscape architect and architect/developer.

### Required content of the Bats and Lighting Response Report

- 1) A summary of off-river bat activity elsewhere within the application site
- 2) Full bat survey data for non-compliant applications
- 3) A summary of baseline illuminance levels, if appropriate
- 4) Lighting Zone boundary maps for the site following application of the River Corridor Lighting Zones
- 5) Details of the light spill mitigation design solutions
- 6) Proposed post development light conditions for the river and bankside vegetation and any other retained or created habitat features
- 7) Planned operational habitat conditions for bats
- 8) Details of habitat management of retained and created habitat features
- 9) Monitoring details proposed to check operational bat activity and light conditions
- 10) Residual impact plan



The following list provides more detail on each of the requirements listed on the previous page.

### 1) Summary of off-river bat activity within the application site

Where conformity with the River Corridor Lighting Zones is demonstrated, bat survey requirements for planning are limited to the clarification of any site specific, off-river bat interests. 'Off-river' is generally defined as all locations outside of Zones A-B as determined by the project ecologist. The relative importance of these locations and their habitats for bats will be need to be determined as part of the wider site ecological assessment, and standard survey methods should be used (Good Practice Guidelines – Bat Conservation Trust, 3rd ed.). Principally, the information should detail the occurrence of any roost sites, foraging areas and associated flight paths leading to or from the river corridor from inland and the results of any further surveys as recommended by the ecologist.

### 2) Full bat survey data for non-compliant applications

Where conformity with the River Corridor Lighting Zones cannot be achieved, a full survey of the site, adjacent land, and riverside areas for bat activity should be undertaken. This information may then be used to support any proposed divergence from the guidance and any design decisions taken which may otherwise lead to impacts upon bats.

Given the value of the river corridor and year-round activity by key species, survey effort will need to be high and should replicate that carried out in the BEA baseline river corridor surveys carried out in 2016/7. This was an adaptation of guidance within the *Bat Conservation Trust's Good Practice Guidelines*.

The following minimum survey standards should be followed:

- One walked 3hr dusk transect per month between the months of April and October inclusive during suitable weather conditions. Transects will focus on land within Zones A and B but consider inclusion of elements of Zone C land where appropriate. Each surveyor should cover no more than a 200m long transect.
- One 3hr dawn transect to be carried out on one occasion between the months of May and September inclusive during suitable weather conditions.
- One automated bat detector to be deployed per Lighting Zone for a period of at least five consecutive nights of suitable conditions each month of the year. For sites with over 50m of riverbank bounding the site, one additional detector to be deployed per zone for every additional 50m (or part thereof) of bounding riverbank.
- All static detector recordings to be manually verified for the presence of horseshoe bats.

A full report discussing the survey findings, an assessment of horseshoe bat presence and appropriate mitigation for divergence from guidance standards to be prepared.

### 3) A summary of baseline illuminance levels, if appropriate

An understanding of baseline illuminance levels will allow accurate comparisons to be undertaken during post development monitoring and compliance checks. This is especially important where existing/ pre-development lighting outside of the applicant's control acts upon the lighting zones within the application site. The need for baseline surveys will be particular to each site and should be informed through collaboration with ecologist and lighting professional based upon their understanding of local on and off site lighting conditions and the proposed lighting scheme. A baseline lighting survey may not be required where there is no existing lighting within or acting on the site, or where all existing lighting on site will be replaced with new lighting detailed in the proposals.

If a baseline illuminance survey is determined to be necessary, the lighting professional should determine the appropriate number and location for sample readings to be taken taking into account the sensitivities of the River Corridor Lighting Zones, the habitats of value to bats on site and the potential need for the samples to be repeated post-development as closely as possible.

Four vertical readings at 1.5m above ground oriented towards the water and at 90, 180 and 270° from this as well as horizontal (ground) measurements should be recorded at each sample location.

An appropriately high quality light meter must be used which is V-Landor and Cosine Corrected and the type of light meter used for the survey must be specified in a baseline survey report (i.e. Minolta T10).

#### 4) Lighting Zone boundary maps for the site following application of the River Corridor Lighting Zones

A plan showing the chosen location and widths of the Lighting Zones proposed for the development should be provided based upon the guidance provided in this document and collaboration with the project ecologist, lighting professional and landscape architect as appropriate. The zonation proposed should reflect the retention or creation of any off-river bat habitat features (to be treated as Zone A/B),

#### 5) Details of the light spill mitigation design solutions

The Bats and Lighting response report should summarise the light spill mitigation strategy adopted by the scheme and then clarify specific measure used. Potential mitigation solutions are set out in Section 8 of this guidance Where a scheme is failing to achieve light spill targets and key mitigation measures are not used, a reasoned justification should be provided.

#### 6) Proposed post development light conditions for the river and bankside vegetation and any other retained or created habitat features

In order to determine conformity with the Lighting Zones, a detailed Lighting Impact Assessment (LIA), including modelled lux contour plots or similar plans displaying illuminance levels within the River Corridor Lighting Zones are required and should be prepared by a suitably competent lighting professional.

The LIA should show the number, location and specification of each luminaire within the development, including its orientation, dimming, shielding, height, recessing, tilt and its output.

The illuminance modelling plots are required and should show the extent of illuminance within the Lighting Zones via a grid array of theoretical sensor points, or by showing isolux contour lines which link areas of the same lux level.

The LIA should contain a discussion of the decision making process, including use of this guidance, and an assessment of the scheme's compliance with it.

Illuminance modelling is required to display data observing the following parameters:

- Land within zones A-C (and any features to be treated as such) to be modelled using a horizontal ground-level calculation plane. Additionally, separate calculation grids should be included to show vertical plane illuminance at 1.5m across the Zones oriented in each of four directions – approximately facing the river, 90° clockwise, 180° clockwise and 270° clockwise . These directions and heights correspond to likely horseshoe bat behaviour and enable lighting from all directions to be accounted for.
- Software used should ideally utilise ray-tracing capabilities and be an industry-recognised package operated by a lighting professional.

- Illuminance calculations will need to combine the outputs of exterior and interior light sources, thereby including the component of light transmitted via windows and other openings. Interior lighting to be modelled in all areas where there is potential for light to emanate through glazing, toward the Lighting Zones. Any light transmission factor applied to the glazing (tinting) should be clearly stated.
- All luminaires apart from those solely used in emergency situations must be included within the modelling and be set to their intended normal output levels during active use. Motion-sensitive or security lighting is not considered emergency lighting and should be included.
- A maintenance factors of 1 should be applied to all lighting calculations and all lumen outputs must be based on a luminaire's Initial Lumens (IL) in order to show its 100% intended 'Day 1' output.

- While soft landscaping planting is highly encouraged and can make a significant impact on attenuating glare and illumination, it cannot be factored in to the illumination models for several reasons. Newly planted vegetation may take several years to become established and may be removed in later years causing problems in enforcing planning conditions. The screening effects of immediate and more permanent barriers such as fences, walls and banks should be factored in by using topographical data within modelling.

#### 7) Planned operational habitat conditions for bats

A plan should be prepared with ecologist input showing the nature and distribution of bat habitat including flight lines, foraging areas, roost sites and swarming sites as appropriate at site operation.

#### 8) Details of habitat management of retained and created habitat features

Details of the nature, timing and frequency of habitat management proposed should be submitted. This should include details of who will be responsible for habitat management and maintenance and how to contact them. (NB. These details can be submitted part of the main site Landscape and Ecology Management Plan (LEMP) where appropriate)

#### 9) Monitoring details proposed to check operational bat and light conditions

In order to ensure the accuracy of modelled lighting and conformity with the Lighting Zones, a post-development lighting survey should be carried out by a lighting professional using a calibrated cosine corrected light meter within three months following completion. This will be required by planning condition.

The survey should be carried out with all lighting active (to replicate the lighting state within the modelling) and notes should be taken as to the output and activity of luminaires observed during the survey. Surveys should be timed to take place on evenings of little moonlight, either due to cloud cover or a new moon. Readings of illuminance should be taken at representative locations within each zone according to the planes and orientations used in the modelled calculations as chosen by the lighting professional. Results and

discussion should be submitted to B&NES in order to discharge the planning condition.

The use of web-based remote construction and operation illuminance monitoring systems to obtain a long-term understanding of the lighting conditions on site may be suitable in some situations. Consultation with B&NES will be required on their locations, relevant illuminance (lux) trigger levels and regularity of required feedback (i.e. a short report which is generated and sent automatically to B&NES once a week)

#### 10) Residual impact plan

An outline of the measures that would be implemented if the proposed operational conditions for bats and lighting are not achieved. This includes failure of landscaping, lighting changes and exceeding of Lighting Zone limits during monitoring exercises.





## 2.5 Design solutions

The following measures should be considered when designing the scheme in order to comply with the River Corridor Lighting Zones and other aspects of this guidance.

### **Mitigating light spill from exterior lighting provision**

- Consider whether any exterior lighting is absolutely required and avoid lighting where unnecessary. The likely uses of the external spaces/routes within a development must be fully understood to determine whether they should be lit after dark, and if so how, to what level and during which hours of use after dark. All of these should be articulated and justified as part of a proposal.

- Consider using barriers to light: light intensity can be reduced in some locations by creating a light barrier to restrict the amount of light spill reaching sensitive area. Barriers can be in the form of walls, bunds or fences. Vegetation can be used to enhance these features, but shouldn't be relied upon in achieving River Corridor Lighting Zone targets.
- Where lighting is unavoidable, seek to reduce light intensity and numbers of luminaires, and ensure the use of the most directional and focussed luminaires available. For example, one-sided bollard luminaires with screens to prevent upward light spill are preferable to traditional 360° un-focussed bollards.
- Careful specification of optics and light shielding/shaping accessories fitted to luminaires as specified by a lighting professional can further reduce light spill.
- Aim to ensure that the Upward Light Ratio (ULR) of the installation is limited to 5% in order to stop poorly aimed luminaires reduce glare.
- Mounting heights should be minimised to reduce the distance light can spill. Along the riverside mounting heights of amenity/street lighting should not exceed 4m.
- Light sources with low blue and low UV content should be employed. Warm colour temperature light sources to be employed preferably at 3000Kelvin. Red or orange lamps with minimal blue component may be appropriate. In preference modern LEDs should be selected as these emit significantly less or no UV light so are less disruptive to both insects and bats (South Hams SAC Advice Note 6).
- Any essential security lighting should exclusively use PIR motion-sensitive luminaires set to short timers of no more than 2 minutes and should be specified to minimise the likelihood of new occupants installing their own.

- Consider the use of Control Management Systems (CMS) to apply dimming regimes during the night to reduce levels of illuminance during periods of high bat activity (typically soon after dusk and the hours pre-dawn) or to ensure lighting only comes on when it is needed – for example being activated by the movement of pedestrians. Colour shifting can also be considered. This should not be at the expense of public safety and could include the use of presence detectors to enable light levels to intensify or light colours to shift when required. E.g. Low levels of amber-red light could be employed along sensitive habitat, with warm white light with increased colour rendering activated to support pedestrian safety and security.
- Lighting of bridges should seek to minimise lighting to that required for public safety, and should consider deck level lighting only, lighting of a single rail only, and all relevant baffles, cowls, and directional lighting etc to avoid light spill onto the water and within Lighting zones A&B.

### **Mitigating light spill from interior lighting provision**

- Building set back and orientation can dramatically reduce the reach of light spill and the encroachment on the Lighting Zones A& B so should be carefully considered with the input of a lighting professional.
- The careful planning of internal building layout and proposed use can minimise the operational light requirements on the riverside areas of buildings.
- The design and depth of window reveals and reduced transparency of glazing can substantially reduce light spill.
- The use of balconies and louvered windows can reduce light spill into the Lighting Zones.
- Tight optical control must be applied to any luminaire within 1.5m of glazing. This includes the use of, for example, 'darklight' type downlights with deep-recessed light sources and focused beams. Diffuse fluorescent type luminaires should be avoided alongside glazing.

- Light spill from ground floor spaces should not extend beyond 1.5m of the glazing line.
- In the case of office lighting, lighting to areas behind waterside glazing should be controlled on a separate lighting circuit to enable them to be switched off or dimmed separately when a different area of the office floor is in use.
- All internal lighting must be switched off when the room is unoccupied – this should be achieved through the use of lighting control systems and/or appropriate building management.
- The use of automated dimming circuits and automated blinds on windows to attenuate light spill is unacceptable due to concerns regarding their long term maintenance.

Not all measures will be appropriate or feasible at any one location but all should be considered and utilised as appropriate. Retrofitting lighting solutions after main design concepts have been progressed should be avoided. Many retrofitting solutions are expensive and compromising of other design requirements.

## 2.6 Managing unavoidable impacts

In limited circumstances, where bat habitat along the river corridor (Zones A-C) or connections to it (Zone C) are at risk of lighting impacts that cannot be mitigated, it may be possible to provide alternative, compensatory dark corridors that can help sustain the function of the river corridor. These circumstances are likely to trigger the need for a full Appropriate Assessment under the Habitats Regulations and any proposals would need to be supported with adequate bat activity survey information.

Dark corridors can be created to encourage/guide bats away from lit areas or around lit obstacles, such as roads. Corridors should be placed with consideration for the use of the landscape as a whole in relation to key commuting routes, linking foraging sites and roosts. Corridors can be composed of man-made or natural materials e.g. fences, brick walls, tree lines or hedges. Corridors with outgrown vegetation are preferable as they create dark fly ways sheltered from predators and the elements. Heavily clipped low hedges/tree-lines are not suitable.

To increase their effectiveness dark corridors should be:

- Well-connected within the bat landscape – linking to existing flight paths, roosts or foraging areas;
- Outgrown with mature vegetation providing shelter for bats from the weather and predators as they fly;
- Planted with native species to encourage insect populations, thereby allowing bats to forage along the corridors.

Early involvement of an ecologist and lighting professional, combined with pre-application advice from the Local Planning Authority and Natural England is advised in order to reach an effective solution.



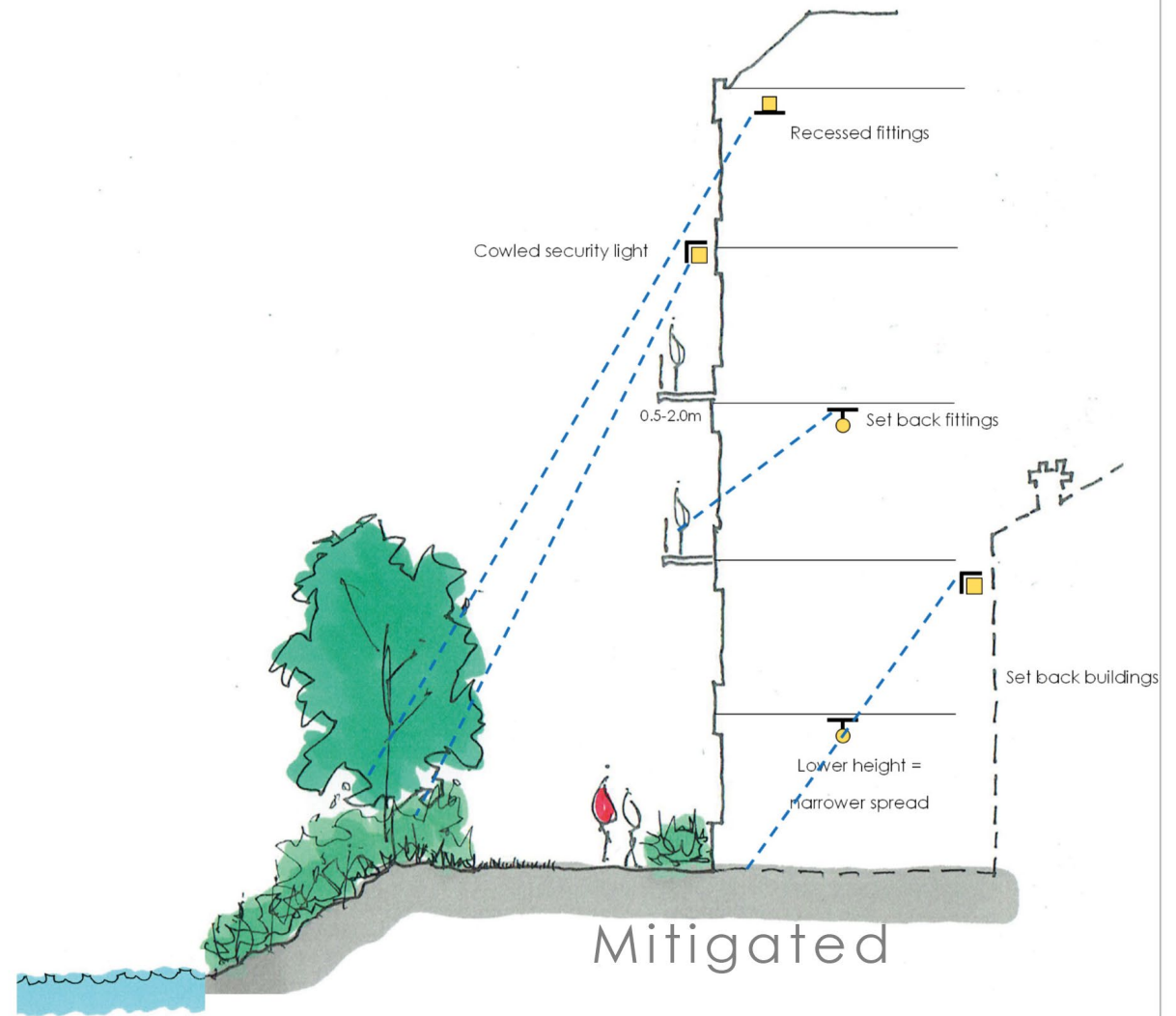
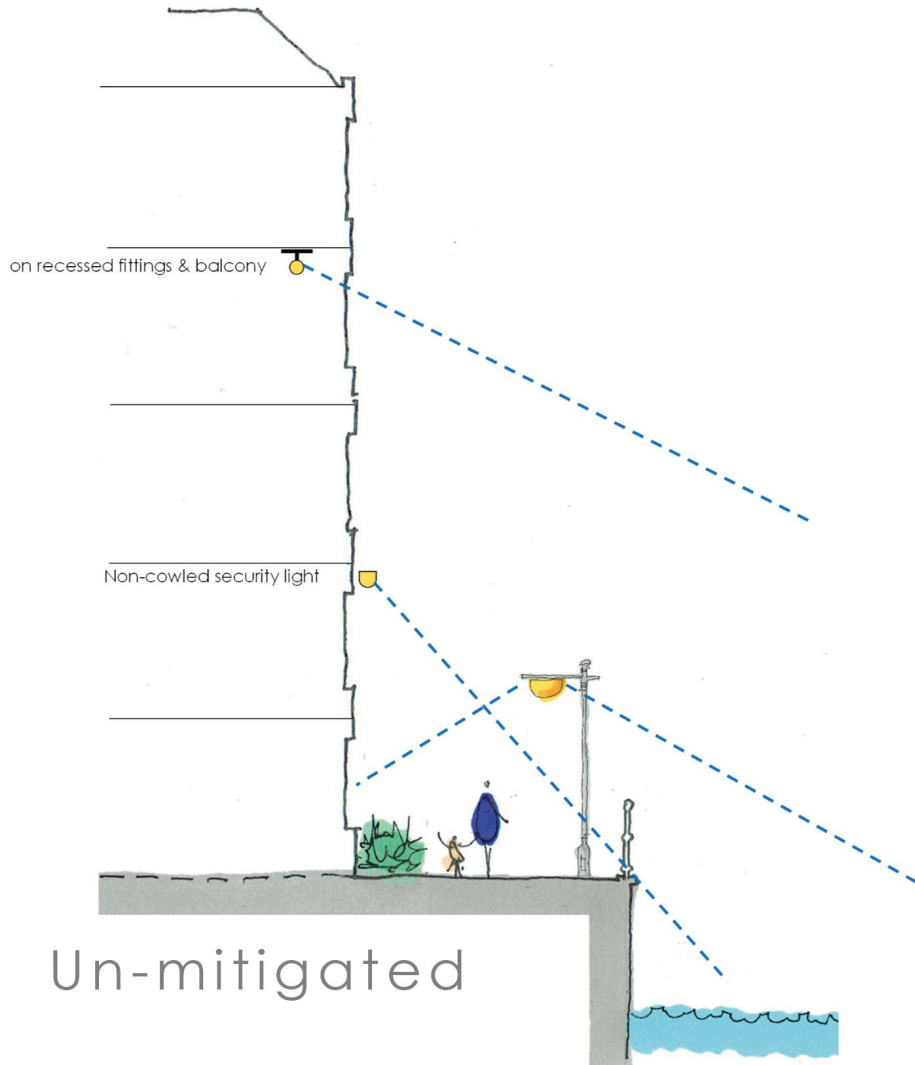
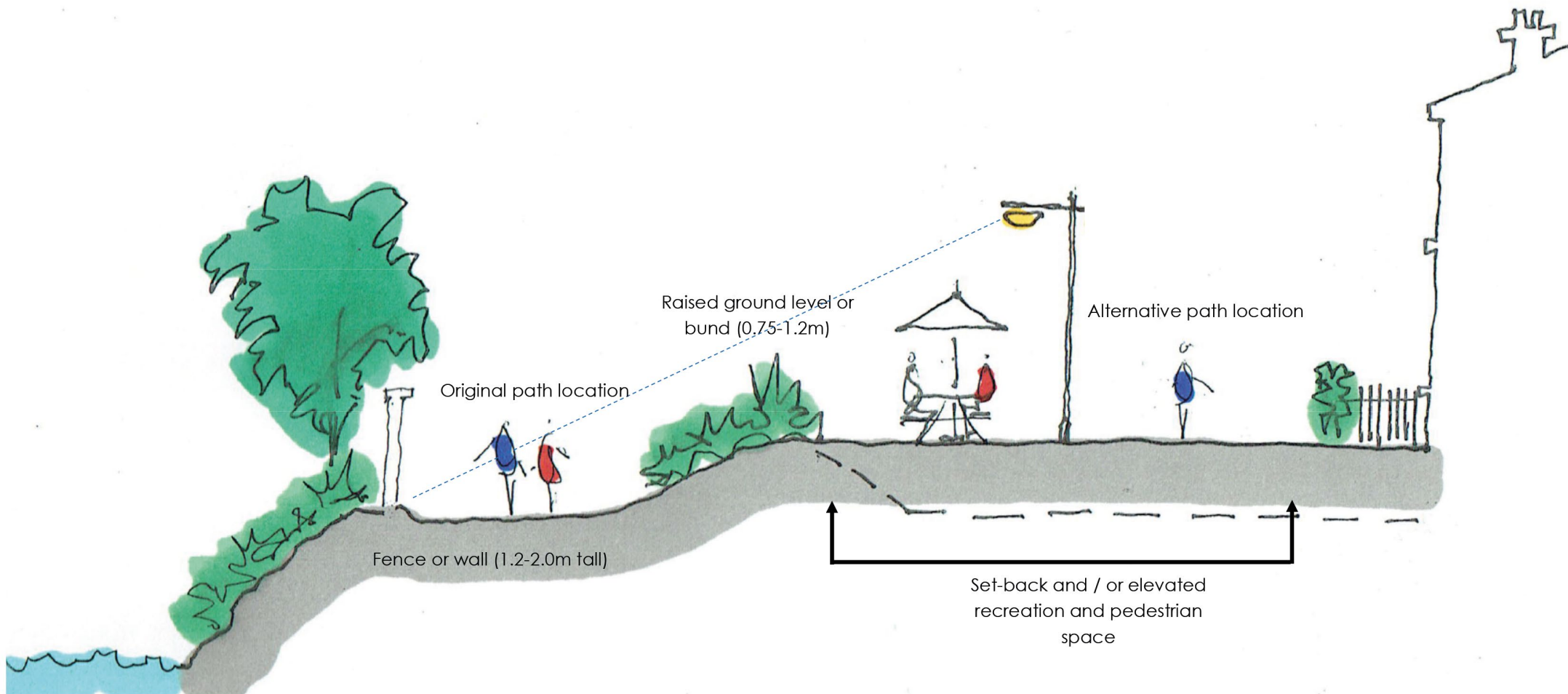
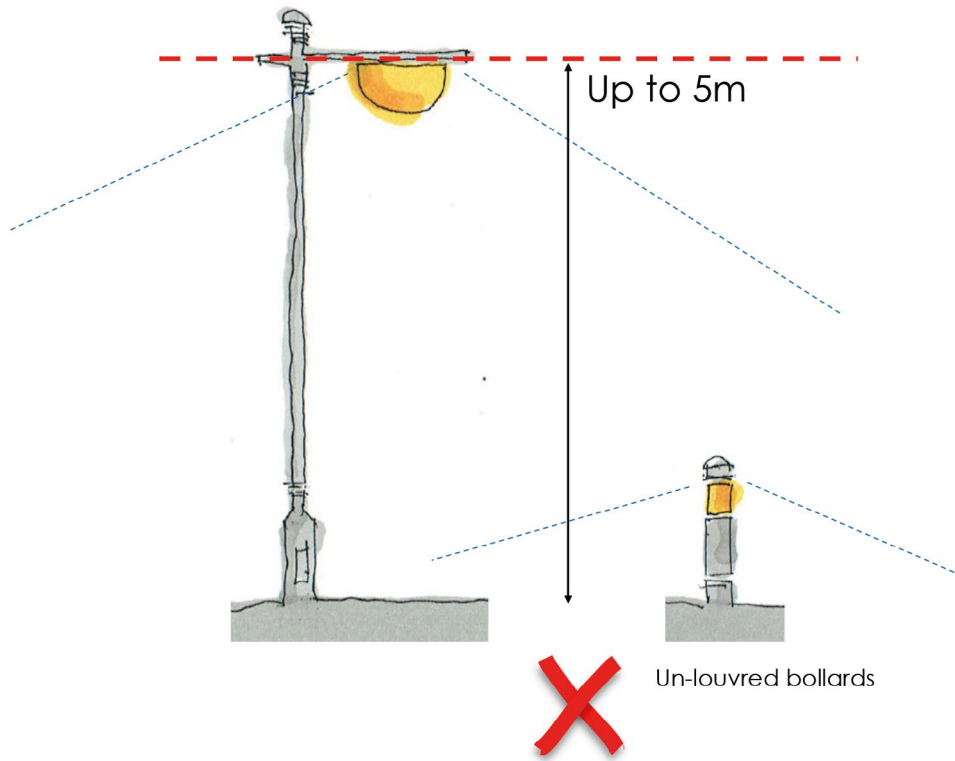

Figure 14 Lighting concepts unmitigated and mitigated scenarios



| **Figure 15** Physical barriers to light & set-back from riverbank zone.



Shorter column = narrower spread  
Increased spacing = fewer fittings  
Baffled & Cowled fixture = directional spread

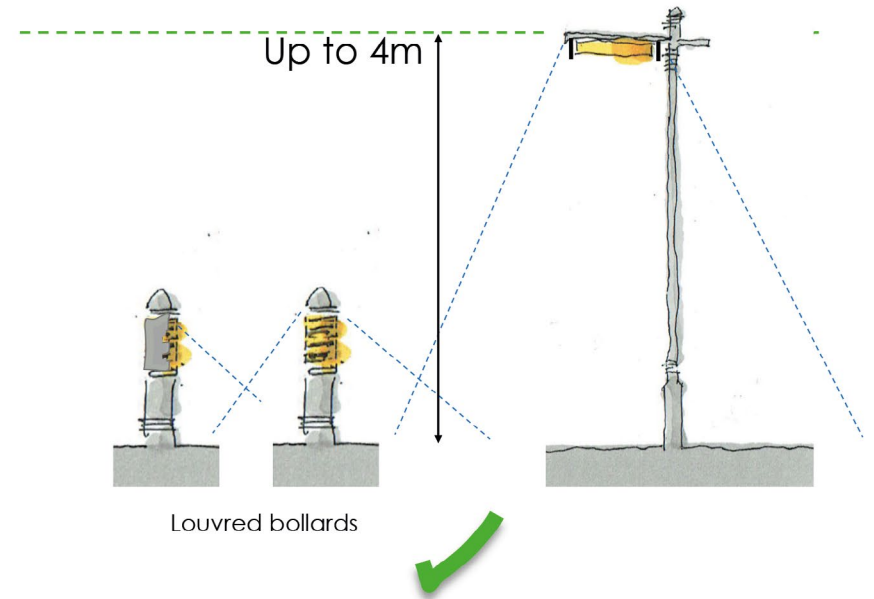
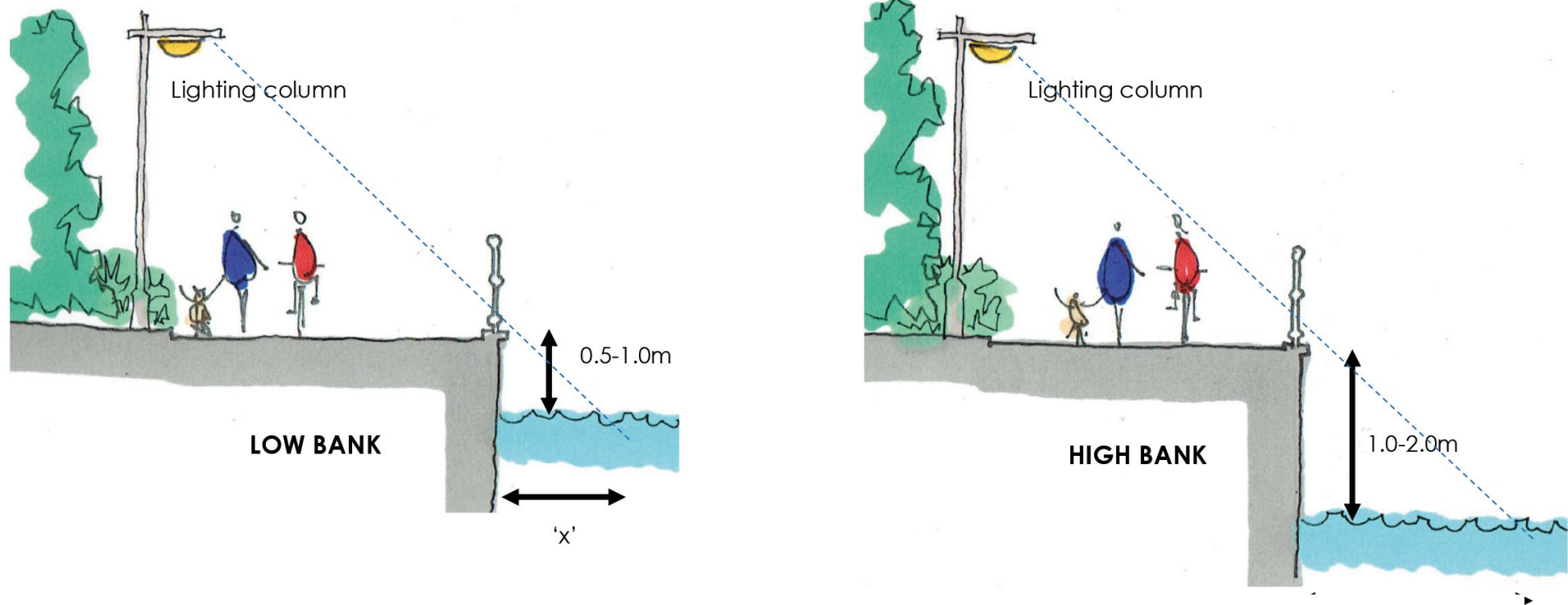
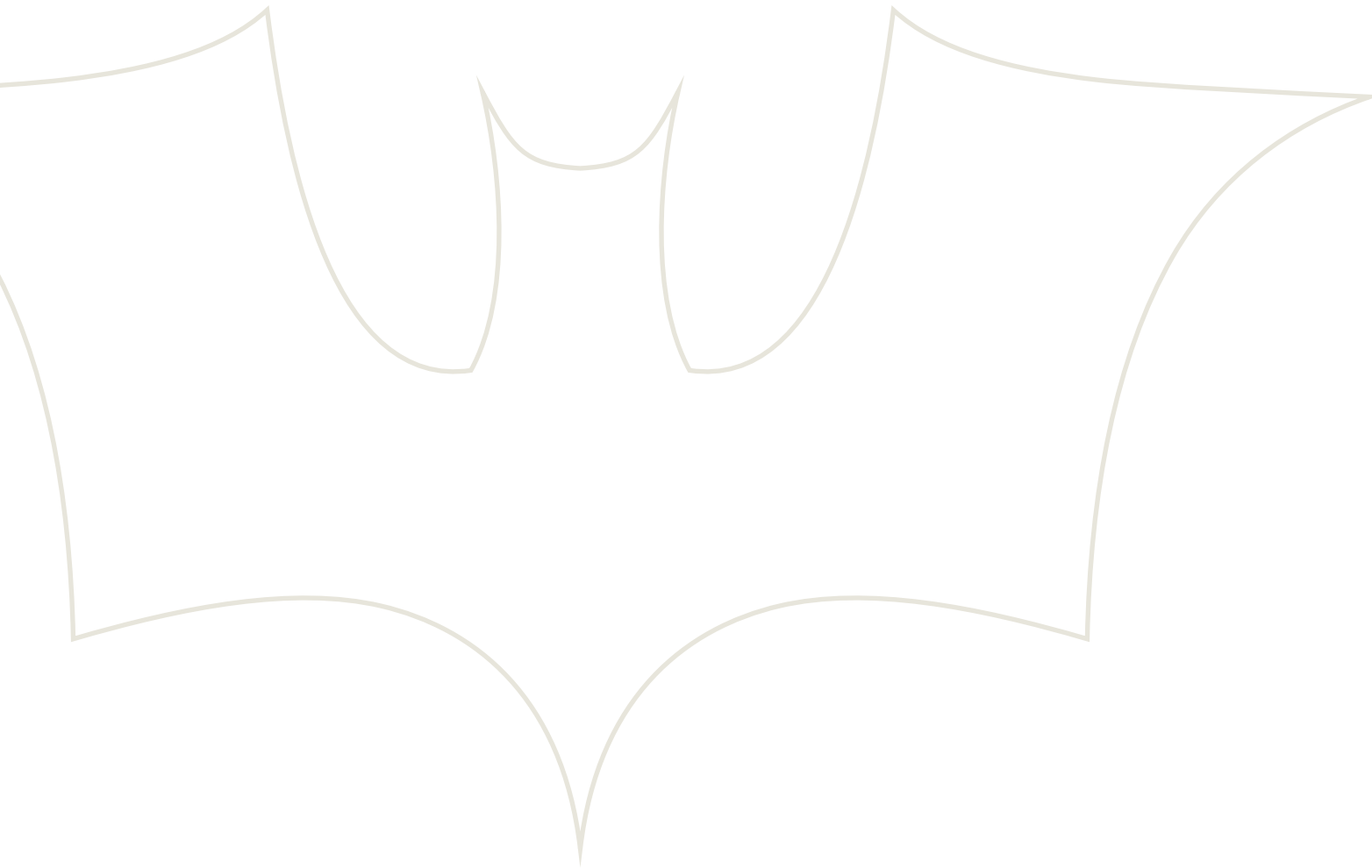

Figure 16 Potential design solutions to help minimise light spill.



| **Figure 17** Diagram to show effect of bank height on bat flight zone and bank shadow.



# Bibliography

Bats and Lighting in the UK,  
Bat Conservation Trust, 2008

Guidance Notes for the Reduction  
of Obtrusive Light GN01: 2011  
(Institute of Lighting Professionals)

UK Road Lighting Standards (2017)

Institute of Lighting Professionals  
website (2017)

Society of Light and Lighting (2017)

Bath City Centre Lighting Strategy,  
which forms part of the Pattern  
Book (2010)

Stone, E. L., Jones, G. & Harris, S.  
(2012) Conserving energy at a cost  
to biodiversity? Impacts of LED  
lighting on bats. *Global Change  
Biology* 18:8





**Bath & North East  
Somerset Council**