

# Energy Efficiency, Retrofitting and Sustainable Construction

## **SUPPLEMENTARY PLANNING DOCUMENT**

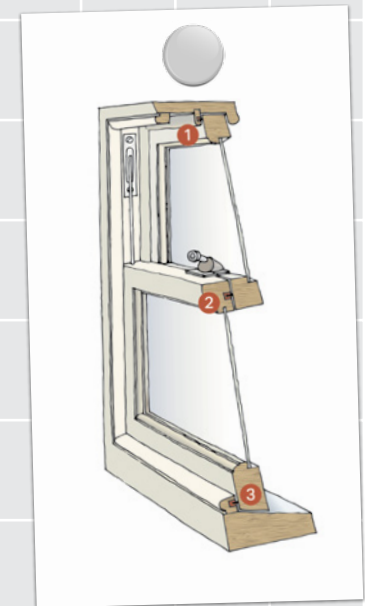
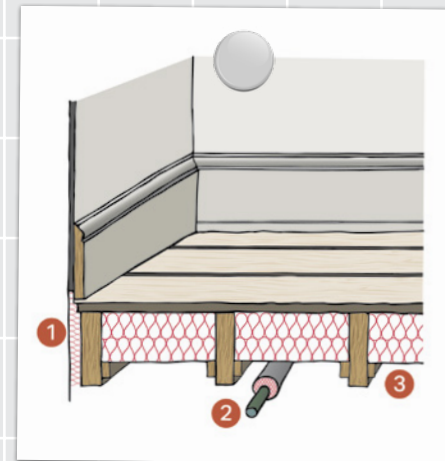
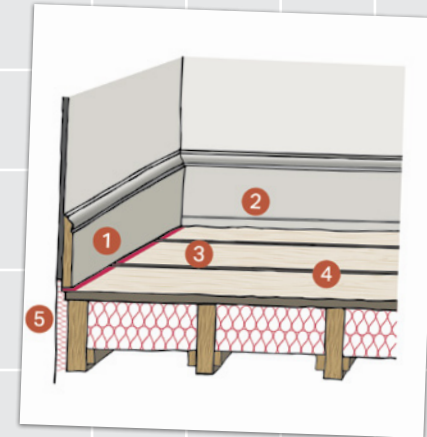
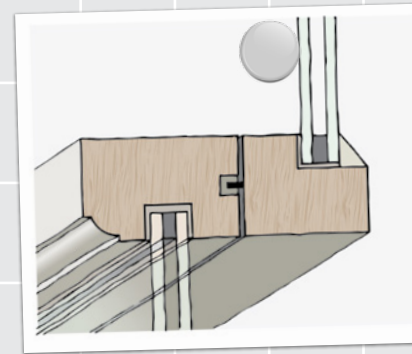

# CONTENTS

<b>Chapter 1: Introduction and Policy Forward</b>	1	Draughtproofing Historic Buildings: Window, Doors, Floors, Skirting Boards, Ceiling and Flues	45
Introduction	2	Secondary Glazing	47
Policy Background	6	Cavity Wall Insulation	59
Energy Saving 'Quick Wins' Checklist	11	Internally Applied Solid Wall Insulation (IWI)	62
<b>Chapter 2: Retrofitting Guidance</b>	13	Externally Applied Solid Wall Insulation (EWI)	65
Retrofitting and its Impact Summary Table	14	Insulating Solid Floors	68
Electric Vehicle Charging Infrastructure (EVCI)	17	Roof Insulation at Ceiling Level	71
Timber Floor Draughtproofing	21	Roof Insulation at Raft Level	74
Timber Door Draughtproofing	24	Insulating Historic Buildings at Loft and Roof Level	77
Timber Floor Insulation	27	Solar Photovoltaics and Solar Thermal	80
Chimney Register Plate	30	Ground Source Heat Pumps	83
Chimney Draughtproofing Balloon	33	Air Source Heat Pumps	87
Metal Framed Window Draughtproofing	36	Boilers and Heating Controls	94
Timber Casement Window Draughtproofing	39	Rainwater Harvesting	97
Timber Sash Window Draughtproofing	42	Greywater Harvesting	100

<b>Chapter 3: Sustainable Construction</b>	101	<b>Chapter 5: Further Information</b>	129
Land-Use & Ecology	102	Further Information	130
Siting & Orientation	105	17 <sup>th</sup> Century Building	132
Passive Design	108	Georgian/18 <sup>th</sup> Century Building	134
Thermal Mass	110	Victorian/Edwardian Building	136
Surface Water Runoff	111	Early 20 <sup>th</sup> Century Building	138
Water	113	Late 20 <sup>th</sup> Century Building	140
Energy	115	What Makes a Good Listed Building Application?	142
Materials	117	Local Heritage Asset Case Studies	147
Waste	118	What Makes a Good Listed Building Application?	160
Legislation & Assessment Tools	119	Useful Resources and Information	163
Case Study: The Nucleus at Hayesfield Girls' School, Bath	122	Glossary	168
<b>Chapter 4: Achieving Affordable Warmth</b>	124		
Heating and Health: The Ambition of Affordable Warmth for All	125		
How to Achieve Low-Carbon Affordable Warmth	127		

**CHAPTER 1:**  
INTRODUCTION AND POLICY FORWARD



# INTRODUCTION

Bath and North East Somerset has declared a climate emergency and has committed to providing the leadership for the District to be carbon neutral by 2030. This will contribute to the UK's legally binding target of net zero carbon by 2050. There are three key priorities to achieve this which are;

- Energy efficiency improvement of the majority of existing buildings (domestic and non-domestic) and zero carbon new build;
- A major shift to mass transport, walking and cycling to reduce transport emissions;
- A rapid and large-scale increase in local renewable energy generation.

This Supplementary Planning Document accompanies the core aims of this resolution, in addition to Bath & North East Somerset's Local Plan and Draught Core Strategy Policies SCR1: Retrofitting and CP2: Sustainable Construction.

## Aims:

- Provide simple, practical guidance on retrofit and sustainable construction for all building types whilst having regard to statutory legislation
- Facilitate all householders and developers to approach build projects more sustainably
- Support the uptake of retrofitting measures
- Support planning, housing, building control and conservation officers to provide consistent and quality advice
- Enable our goal of achieving 65,000 retrofits in B&NES by 2030.
- Enable affordable warmth for all

## Retrofitting

The Council seeks to encourage retrofitting measures to existing buildings to improve their energy and water efficiency and their adaptability to climate change. Support for appropriate domestic scale renewables is also important.

# INTRODUCTION

This document profiles the main building types found in Bath & North East Somerset and explains through diagrams how they are built and what materials are used (see **Chapter 5 'The Different Building Types in B&NES'**, for further guidance)

At the end of this Introduction Chapter you can find a **'Energy Efficiency 'Quick Wins' Checklist'** which provides cheap or free energy & water improvement solutions which home owners and occupiers can implement immediately.

You can then consider which retrofitting options you might like to consider (see **Chapter 2**).

The Council encourages and enable the sensitive retrofitting of energy efficiency measures and the appropriate use of microrenewables in historic buildings (including listed buildings) and in Conservation Areas whilst also safeguarding the special characteristics of these heritage assets.

## **Energy Efficiency and the Historic Environment**

It is widely recognised and accepted that the historic environment should play its part in meeting these current and future challenges. However, it is vital that changes are consistent with the aims of heritage protection and the statutory duty of care placed on the Local Planning Authority (LPA) by primary legislation and Government policy.

In accepting that some change will be necessary, it is critical that this is carefully managed so that the historic environment and the heritage assets that it is made up of is sustained as cultural heritage for present and future generations. Historic buildings are a finite resource and are inherently sustainable having been, in most cases, well-constructed from high quality, locally sourced materials by local craftsman.

Their inherent embodied energy (the energy expended and encapsulated within the fabric of a building in its construction) means that their retention and care is both logical and consistent with modern concepts of sustainability and with the ambitions of reducing carbon emissions.

# INTRODUCTION

## **Traditional buildings and their need to 'breathe'**

It has been long recognised that traditionally constructed buildings utilising a solid wall construction (generally considered as buildings constructed before 1919) need to be able to 'breathe'.

The word 'breathe' in this sense means permeability and the ability of moisture to move freely, unhindered, throughout the width of the wall. This mechanism relies on moisture being able to evaporate into the external and internal atmospheres.

Internally moisture evaporates and enters the internal environment and relies on good ventilation to be evacuated into the external atmosphere. This process is critical for the health of the building and its occupants and relies on a number of factors in order to function properly including: permeable materials such as lime mortar, lime plaster, traditional permeable paint finishes and traditional, passive ventilation routes such as chimney flues and natural ventilation in doors and windows.

If non-permeable materials are used such as cementitious mortar, gypsum plaster, modern impermeable paint finishes and traditional ventilation routes are blocked then this will result in high levels of moisture and condensation to the detriment of the health of the building and its occupants. High levels of moisture trapped in masonry walls will lead to increased heat loss, discomfort for the occupants and may harm interior fixtures, fittings, finishes and structural timbers.

Whilst it is recognised that excessive draughts can cause discomfort for the occupants of a building it also needs to be recognised and understood that hermetically sealing a traditional building, in the manner of modern building construction, could cause significant problems for occupants and buildings alike. In proposing thermal upgrading measures an understanding of the needs of a traditionally constructed building need to be understood. For instance, care must be taken when improving thermal efficiency through draught proofing not to create a barrier to a sufficient level of ventilation.

# INTRODUCTION

The LPA advocates that owners of traditionally-constructed buildings undertake an assessment of the needs of the building based on a thorough understanding of how it is constructed and how it is ventilated.

## **Sustainable Construction**

The Council would like to ensure that all design, construction and build projects use Sustainable Construction principles. For larger scale developments, specialist expertise can often be employed or known methodologies can be used such as Code for Sustainable Homes, Passivhaus or the Building Research Establishment Environmental Research Methodology (BREEAM) – explained further in **Chapter 4**.

However, there are opportunities for almost all build projects, large or small, to be more sustainable and this document introduces and explores, in pictures, the key Sustainable Construction principles. These principles are founded on the well-established methodologies.

## **Tackling the Climate Emergency**

Bath and North East Somerset Council acknowledge the urgency to act to address the rising global temperatures and changing climate. To enable the scale of the Climate Emergency ambition to be realised, it will require a shift in the way we adapt and construct buildings; this SPD sets out ways to achieve this. However, in this context, new technological solutions are regularly coming onto the market and so, if a retrofitting or sustainable construction measure isn't covered within this guidance, we still encourage you to explore these options and seek our advice as to whether planning permission or listed building consent is required. We will assess these cases individually on a case-by-case basis.

# POLICY BACKGROUND

## National Planning Policy Framework

The NPPF places significant emphasis on achieving sustainable development and core environmental principles such as improving biodiversity, using natural resources prudently, minimising waste and pollution and mitigating and adapting to climate change including moving to a low carbon economy (paragraph 8). These principles underpin this Supplementary Planning Document.

## The Wider Council Policy Context

As a council, we declared a Climate Emergency in March 2019, an Ecological Emergency in July 2019. Our current planning framework was agreed in 2014 before we declared climate and ecological emergencies. It is therefore essential we update our planning policies to reflect these commitments.

[Read more about our work on the Climate Emergency](#)

## Bath & North East Somerset Council's local policies

Bath & North East Somerset Council is currently in the process of undertaking a Local Plan Partial Update. Therefore, whilst the guidance in this SPD supplements the following local policies in the placemaking plan, they will be subject to change as new policies emerge through the Partial Update and this section of the SPD will be updated accordingly.

## Local Plan

Policies of particular relevance are likely to be D1-10 Design Policies; and BH2 and BH5 in relation to listed and historic buildings.

This SPD also supplements policies CP1 on Retrofitting; CP2 on Sustainable Construction; and CP3 on Renewable Energy.

## Historic Buildings Legislative Background

Designated heritage assets are protected by law under Planning (Listed Building & Conservation Areas) Act 1990 underpinned by Government policy: National

## POLICY BACKGROUND

Planning Policy Framework, Section 16: 'Conserving and enhancing the historic environment'. They are designated in recognition of their architectural or historic interest and the heritage and cultural significance and value that they possess.

The setting of heritage assets is an important material consideration when determining planning applications for development proposals which impact on their setting. Heritage assets are wide ranging and include designated and undesignated buildings, conservation areas, historic landscapes, parks and gardens and archaeological features and sites. Archaeological sites and features that have been designated as Scheduled Ancient Monuments are protected by law under the Ancient Monuments and Archaeological Areas Act 1979.

Central to primary legislation and Government policy is the special regard to the desirability of preserving heritage assets or any features of special architectural or historic interest. This SPD includes detailed guidelines on how to sensitively implement energy efficiency interventions in heritage assets to make it more likely

that the intervention will comply with legislation and be looked upon favourably by the LPA.

This guidance is informed and consistent with this and with conservation best practice and responsible retrofitting as advocated by Historic England and the national amenity societies. Consistent with Government policy relating to the historic environment this guidance recognises that because heritage assets can be both designated and undesignated an equally sensitive and thoughtful and sensitive approach to change should be employed to both. This is particularly the case in Bath & North East Somerset which has large numbers of designated and undesignated assets. Designated assets include the City of Bath World Heritage Site, as well as numerous Conservation Areas and Listed Buildings.

## POLICY BACKGROUND

This SPD will include guidance for 'Heritage Assets', which applies to both undesignated and designated heritage assets. Consistent with the definition in NPPF guidance, our reference to 'Heritage Assets' applies to the following:

- **Heritage Asset:** A building, monument, site, place, area or landscape identified as having a degree of significance meriting consideration in planning decisions, because of its heritage interest. It includes designated heritage assets and assets identified by the local planning authority (including local listing).
- **Designated Heritage Assets:** A World Heritage Site, Scheduled Monument, Listed Building, Registered Park and Garden, Registered Battlefield or Conservation Area designated under the relevant legislation.

### Guidance Position for Retrofitting Heritage Assets

- There is a duty under Section 16 of the Planning (Listed Buildings and Conservation Areas) Act 1990, when considering whether to grant listed building consent for any works and under Section 66 of the

Planning (Listed Buildings and Conservation Areas) Act 1990 in considering whether to grant planning permission for development which affects a listed building or its setting, to have special regard to the desirability of preserving the building or its setting or any features of special architectural or historic interest which it possesses.

- There is a duty under Section 72 of the Planning (Listed Buildings and Conservation Areas) Act 1990 to pay special attention to the preservation or enhancement of the character of the surrounding conservation area.
- The effect of an application on the significance of a non-designated heritage asset should be taken into account in determining an application. National Planning Policy Framework paragraph 197.
- In the context of these parameters set by the statutory scheme and the NPPF requirements for heritage assets:



## POLICY BACKGROUND

- In the light of the climate emergency, alterations will be permitted and encouraged on listed buildings with special regard to the desirability of preserving the building or its setting or any features of special architectural or historic interest which it possesses; which preserve or enhance the character of a conservation area and which respect the significance of any non-designated heritage asset.
- We will seek to proactively assist in finding solutions and techniques for retrofitting to achieve this wherever possible and give due consideration also to the balance of public benefits of any proposal as required by the NPPF.

Guidance is set out in this SPD, with the benefit of illustrations and case studies, which have special regard to the desirability of preserving the building or its setting or any features of special architectural or historic interest which it possesses; which preserve or enhance the character of a conservation area and which respect the significance of any non-designated heritage asset.

### **Aims and limitations of the guidance**

Whilst this guidance aims to provide advice and assistance regarding alterations to heritage assets it should not be regarded as providing a 'one-stop-shop' or 'one-size-fits-all' solution. Historic buildings are highly diverse in terms of type of construction, construction materials, plan form, degree of alteration over time and location and so planning decisions will be considered on a case-by-case basis.

It is recommended that specific and detailed guidance provided by Historic England and other heritage organisations is also consulted; this is referenced on each of the retrofitting pages within the 'Further Guidance' boxes, and more information is also provided within **Chapter 5: Further Information and Useful Resources**. The LPA can provide further assistance. The energy hierarchy and minimal intervention approach as advocated by Historic England is advocated in this guidance; information on this approach can be found on the **Key Considerations** page at the end of this chapter. There will be an expectation that, in



## POLICY BACKGROUND

the first instance, low impact, low cost and simple thermal upgrading measures are considered before higher impact measures consistent with the energy hierarchy, which include occupant behaviour and sensible and responsible building maintenance.

### **Proportion of Planning Approvals in B&NES**

It is important to note that the vast majority of planning and listed building applications in B&NES are consented. In the year between April 2020 and 2021, the percentage of planning approvals in B&NES were as follows:

- The percentage of approved planning applications was 92%
- The percentage of approved listed building applications was 94%

This SPD aims to continue to this positive trend in relation to energy efficiency, renewable energy, retrofitting, and sustainable construction development proposals; this document provides practical advice which sets out how changes and adaptations can be made in response to Climate Change whilst also having regard to statutory legislation.

# ENERGY SAVING 'QUICK WINS' CHECKLIST

## What are 'Quick Wins'?

On these pages you can find cheap, or free, energy & water improvement solutions which home owners and occupiers can implement immediately. They are non-intrusive measures, meaning they do not require Planning or Listed Building consent, and they can be done without the advice or service of a professional.

### Further Guidance:

[120 Ways to Save and Conserve Energy, for a Greener Planet](#)

Energy Saving Trust:

[Quick Tips to Save Energy in Your Home](#)

[Top Tips to Save Energy](#)

Friends of the Earth:

[13 Best Ways to Save Water](#)

GreenMatch:

[12 Energy Saving Tips for Your Home](#)

## ENERGY SAVING 'QUICK WINS' CHECKLIST

### Tips to save energy and water



Find and cover draughts in your home; draughts are most likely to be found around windows and doors, and through floorboards, your chimney, and the roof.

Use cardboard ready for recycling (for example, loo roll centres are effective) to fold up and wedge in between floorboards or cut strips of felt to poke into the gaps with a ruler. Also, silicone sealant can be used in very thin gaps and timber offcuts are effective in very large gaps.

Stuff old tights or cut-up trouser legs with old clothes to make a draught excluder for doors.

Attach strips of thick fabric, felt, or belts to the edge of doors and windows to create effective and attractive draught excluders.

Cover letter boxes with fabric attached at the top.

Hang curtains over windows and doors. Use old blankets or fabric slung over wooden poles and hooks if you do not have a curtain rail. Use an old white sheet as curtains if you want to block draughts from a door or window without losing daylight coming through panes of glass.

If your home does not have any, or enough, roof or loft insulation, place old blankets and duvets in the loft in between the rafters. Ensure rafters are left visible where there is no floor in the attic space.

Get a free energy meter from your utility company to be able to track electricity usage. Reduce your use of the most energy intense appliances e.g. tumble driers.

Wear layers of warm clothing like slippers and jumpers instead of increasing the thermostat.

Use a washing line, either outside or inside above the bath, instead of the tumble drier.

Use a bucket to collect and re-use the water from a condensing tumble drier to wash the car, water plants, for cleaning, and more.

Use a washing up bowl or plug in the kitchen sink instead of leaving the tap running whilst washing up.

Stuff old clothing and newspapers into a bin bag or garden bag and wedge into the chimney space of open fireplaces. Remember to leave a piece of fabric or cord hanging down so you can easily remove the bag when you want to light the fire. This creates a DIY chimney balloon to stop draughts without blocking amounts of ventilation getting through. This is essential in old buildings to prevent condensation and mould. Put a note in the fireplace to remind yourself to remove the balloon before lighting a fire!

Use water butts or buckets outside to collect water for other uses; this is a DIY rainwater harvesting system.

**CHAPTER 2:**  
RETROFITTING GUIDANCE

# RETROFITTING AND ITS IMPACT SUMMARY TABLE

## Key Considerations

### Key:

L – Low (cheap to install; good Environmental rating)  
 M – Medium (mid-range price to install; very good Environmental rating)  
 H – High (may be expensive to install; excellent Environmental rating;  
 excellent suitability for Scalability)

Retrofitting Measure	Impact			
	Cost	Environmental Rating	Consents Required	Scalability
Electric Vehicle Charging Infrastructure	M	H	LBC (not normally)	H
Timber Floor Draughtproofing	L	L	LBC (not normally)	Not suitable for scaling
Timber Door Draughtproofing	L	L	LBC (not normally)	Not suitable for scaling
Timber Floor Insulation	LM	M	LBC (not normally), BC	Not suitable for scaling
Chimney Register Plate	L	L		Not suitable for scaling
Chimney Draughtproofing Balloon	L	L		Not suitable for scaling
Metal Framed Window Draughtproofing	L	L	LBC (not normally), BC	Not suitable for scaling
Timber Casement Window Draughtproofing	L	L	LBC (not normally), BC	Not suitable for scaling
Timber Sash Window Draughtproofing	L	L	LBC (not normally), BC	Not suitable for scaling
Draughtproofing Historic Buildings	L	LM	LBC (not normally), BC	Not suitable for scaling
Secondary Glazing	M	M	LBC (not normally), BC	Not suitable for scaling
Slim Profile Double Glazing	MH	MH	LBC (not normally), BC, PD, P	Not suitable for scaling

# RETROFITTING AND ITS IMPACT

## SUMMARY TABLE

Retrofitting Measure	Impact			
	Cost	Environmental Rating	Consents Required	Scalability
Double and Triple Glazing	MH	H	LBC (not normally), BC, PD, P	Not suitable for scaling
Reinstate Missing Shutters	LM	LM	LBC (not normally)	Not suitable for scaling
Cavity Wall Insulation	M	H	LBC (not normally), BC	Not suitable for scaling
Internally Applied Solid Wall Insulation	H	H	LBC (not normally), BC	Not suitable for scaling
Externally Applied Solid Wall Insulation	H	H	LBC (not normally), BC, PD, P	H
Insulating Solid Floors	M	M	LBC (not normally)	Not suitable for scaling
Roof Insulation at Ceiling Level	L	H	LBC (not normally), BC	Not suitable for scaling
Roof Insulation at Raft Level	L	H	L LBC (not normally)BC, BC, PD, P	Not suitable for scaling
Insulating Historic Buildings at Loft and Roof Level		H	LBC (not normally), BC, PD, P	Not suitable for scaling
Solar Photovoltaics and Solar Thermal	H	PV – MH, Thermal – M	LBC (not normally), BC, PD, P	H
Ground Source Heat Pumps	MH	LMH	LBC (not normally), BC, PD	H
Air Source Heat Pumps	H	M	LBC (not normally)	Not suitable for scaling
Mechanical Ventilation and Heat Recovery	H	LM	LBC (not normally), BC, PD, P	Not suitable for scaling
Boiler and Heating Controls	M	H	LBC (not normally), BC, PD, P	Not suitable for scaling
Rainwater Harvesting	M	M	LBC (not normally), PD, P	Not suitable for scaling
Greywater Harvesting	M	M	LBC (not normally), BC	Not suitable for scaling

## RETROFITTING AND ITS IMPACT SUMMARY TABLE DEFINITIONS

### Consents Required

*Please refer to the retrofitting guidance sheet pages on each measure for more nuanced & detailed guidance on planning consents; for some measures, in certain cases, the consents in the table may not always be necessary.*

**PD: Permitted Development** – Subject to meeting General Permitted Development Order criteria, you may be able to undertake this measure without planning permission. Certificate of Lawfulness application is advised for certainty.

**PP: Planning Permission** – Submit a planning application which will be assessed against relevant planning policies. We recommend using our pre-application service if unsure.

**LBC: Listed Building Consent** – Where this symbol appears, LBC is required if your house is a Listed Building.

**BC: Building Control** – It is likely the works will have to meet building regulations.

**Scalability** refers to how easily the retrofitting measure could be replicated at a bigger scale – such as whole street or neighbourhood scale. Those rated with a 'High' suitability are an effective way to retrofit whole streets, or with neighbours.

**Please note: Environmental Rating** may be dependent on a number of factors such as the efficiency and carbon emissions of the fuel source you choose. **Cost** can also be influenced by a number of factors and, for some measures, grants and incentives are available. Refer to the retrofitting guidance sheet pages on each measure for more detailed information.

# **ELECTRIC VEHICLE CHARGING INFRASTRUCTURE (EVCI)**

## **What is it?**

An electric vehicle is powered by an electric motor using rechargeable batteries. Electric vehicles offer an excellent opportunity to address the Climate Emergency because they have significantly lower carbon emissions compared to traditional fuel-powered vehicles. They also help to reduce vehicle running costs, meaning you could make a return on the initial upfront cost of your investment.

Electric vehicles function by plugging into a charge point and taking electricity from the grid. Therefore, a high-quality network of charge points where people regularly park is essential to unlocking electric vehicle uptake. Knowing that charge points are available, both at homes and within a range of public places, gives residents and visitors the confidence to purchase or lease an electric vehicle, supporting B&NES's air quality initiative and goal of achieving net zero carbon by 2030.

Ideally, charging infrastructure for electric vehicles should be integrated within new developments from the design and construction stage; this ensures that charge points are conveniently placed, and it is usually less expensive than installing charge points at a later date. However, it is also possible to retrofit EVCI by integrating it into existing developments.

## **Some of the benefits of having a home electric vehicle charge point:**

- Unlike a conventional plug socket, a charge point communicates directly with your car, making charging at home much safer;
- Ease of access and convenience – making electric vehicles a more practical option;
- Charging time is reduced by 30-60%, depending on the car, making charging at home much quicker.



# ELECTRIC VEHICLE CHARGING INFRASTRUCTURE (EVCI)

## Planning Advice

The Town and Country Planning (General Permitted Development) (Amendment) (England) Order 2011 introduced permitted development rights for EV charge points in off-street public and private car parking areas (Part 2 Class D & E). Specifically, charge points can be installed, altered or replaced in areas of off-street parking if:

- they are not within 2 metres of the highway;
- 'upstands' (i.e. bollards) do not exceed 2.3 metres in height, or 0.2 cubic metres if wall-mounted;
- they are not within a site designated as a scheduled monument, or within the curtilage of a listed building; there is not more than one upstand for each parking space.

In situations not covered by these permitted development rights, planning permission is required in order to install charge points. Generally, EV charge points are more likely to be accepted if they are: well-designed charge point units (i.e. sensitive to context, with minimal

street clutter and impact on street scene); placed so they do not create excessively-narrow pavements; and have minimal lighting and signage around the unit.

## Heritage Assets

### Is listed building consent required?

Listed building consent **is required** for EVCI.

#### Guidelines for Heritage Assets:

- Choose a discreet location for any associated equipment
- Be mindful of the setting of heritage assets and the requirement to preserve or enhance the character and appearance of the conservation area
- Avoid physically altering a heritage asset where possible and, where this is unavoidable, minimise the damage and loss of historic fabric.
- Consult the Council's Conservation and Planning Team at the earliest opportunity to seek specialist advice.

# ELECTRIC VEHICLE CHARGING INFRASTRUCTURE (EVCI)

## Help with the cost

The EVCI cost-saving schemes mentioned below may be subject to change in terms of both eligibility and availability over time. We also encourage you to look online for the latest advice on current EVCI funding initiatives.

### 1. **Electric Vehicle Homecharge Scheme (EVHS):**

The UK government encourages the use of EVs by providing funding towards the cost of installing an electric charging point at a residential property.

**2. Workplace Charging Scheme:** The Workplace Charging Scheme (WCS) is a voucher-based scheme that provides support towards the up-front costs of the purchase and installation of electric vehicle charge-points, for eligible businesses, charities and public sector organisations.

[Find out more about these Government grant schemes for EVCI and more here](#)



A discreetly-located Electric vehicle charging point within a residential curtilage in Bath.

To get the best deal for home charging, it's important to get the right electric vehicle electricity tariff. Many providers now provide competitive deals for electric vehicle charging. We recommend comparing quotes.

# ELECTRIC VEHICLE CHARGING INFRASTRUCTURE (EVCI)

## Further guidance:

To check grid capacity before installing EVCI, use this map provided by **Western Power Distribution (WPD)**: [Western Power Distribution - EV capacity map](#). Alternatively, contact WPD directly on: 0800 096 3080

**B&NES's** emerging Electric Vehicle Charging Strategy: [Electric Vehicle Charging Strategy](#)

**Revive** is one of the main charging networks in the West of England (which includes charge points in Bristol, South Gloucestershire, Bath and North East Somerset, and North Somerset), set up by the LPAs. See: <https://travelwest.info/electric-vehicles/charging-points>

- The **Energy Saving Trust** provides practical guidance on electric vehicles and EVCI. See:
  - [Positioning ENVI](#)
  - ['All you need to know about electric vehicles'](#)
  - [Charging Vehicles Best Practice Guide](#)

## TIMBER FLOOR DRAUGHTPROOFING

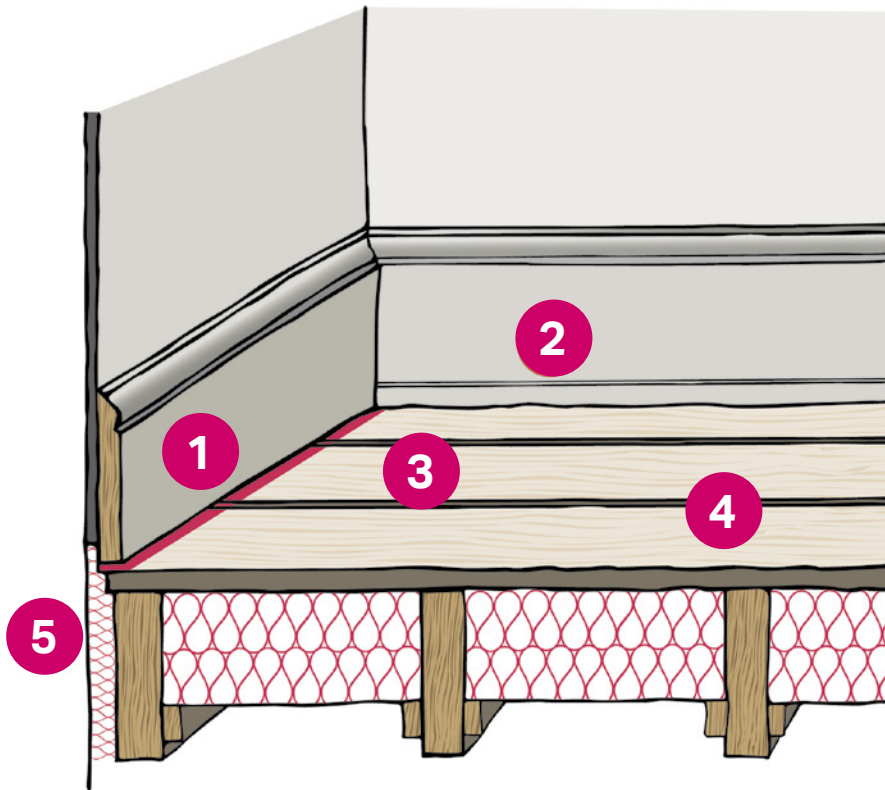

**1.** Caulking smaller gaps with plaster, decorator filler, or mastic can be an effective way to close air-paths between the interior and a floor void.

**2.** With larger gaps, where floors have 'relaxed' for example scribed timber fillets may be necessary to effectively close the joint.

**3.** Hardboard coverings and underlays beneath carpets can also be effective at reducing draughts

**4.** Many timber floors have gaps between the boards through which air can pass; especially those with older plain-edged and butt-jointed boards. Closing these gaps with a compressible caulking strip (preferable as it allows expansion and contraction of the boards) a filler, mastic or timber slips will help prevent draughts. In severe cases it may even be necessary to lift and relay the boards. Although exposed timber floors are very popular today, it is worth remembering that many were not intended to be 'on show' and their quality of materials and workmanship reflected this.

**5.** Floor voids and the spaces behind cornices, panelling and the like should be insulated as described elsewhere.

Where there are larger gaps, these can be sealed with compacted compressible insulation such as mineral wool or sheep wool.

## TIMBER FLOOR DRAUGHTPROOFING

### What is it?

At the edges of a building the places where walls and floors meet afford many opportunities for heat energy to be lost through small gaps. Cold air can enter the building through 'infiltration' commonly referred to as draughts. Heat can also be lost from the interior through 'exfiltration'. The arrangement of floor carpentry typically inserts timber joists or wall-plates into the external walls and as these materials behave differently to the masonry, over time cracks and gaps can appear between them. Air paths are then created through the building fabric. In some older buildings there may also be bonding timbers, lintels and brackets for features such as panelling and cornices; all of which can introduce further gaps in the building fabric.

Often the masonry of the walls is not as well put together in the smaller spaces between these built-in timbers. Mortars and plasterwork may also be less complete. This means that in the region of a floor, the wall itself may have significantly more gaps than elsewhere on the building. Internally, room joinery such

as panelling, shutters and skirting boards can become less closefitting over time as the floors and walls of a building move and age. Plaster finishes can also crack and open up behind elements of the building prone to impact – such as skirting boards. This opening up of the elements of a building introduces further gaps through which air can pass.

### How effective is it?

The effectiveness of draughtproofing at the perimeter of timber floors will vary from building to building, due to their different arrangement of construction and relative condition or state of repair. Typically, floor to wall junctions are 5-7% of the building exterior, but uninsulated and draughty construction will contribute proportionately more to the heat loss. Simple upgrade measures here can therefore be remarkably effective.

For specific **Heritage Asset** guidance on draughtproofing measures please refer to the [Draughtproofing Historic Buildings: Windows, Doors, Floors, Skirting Boards, Ceiling and Flues](#) page of this SPD.

# TIMBER FLOOR DRAUGHTPROOFING

## What does it cost?

Draughtproofing timber floors can be very cost effective as the measures normally involve low cost materials that can easily be DIY installed. Where concealed by joinery, decorative finishes and carpets the appearance of the measures is less important than their function and this also reduces the cost of installation.

### Further Guidance:

[Centre for Sustainable Energy Draughtproofing Leaflet](#)

[Centre for Sustainable Energy: DIY Draughtproofing](#)

## TIMBER DOOR DRAUGHTPROOFING

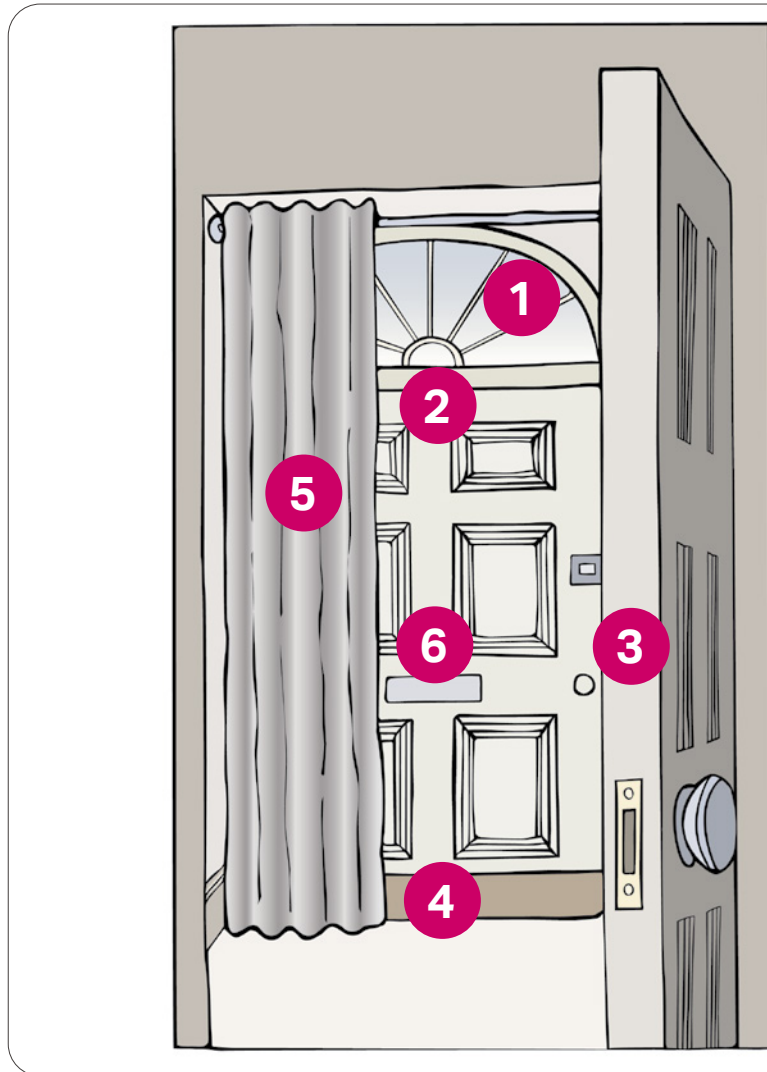

- 1.** Over door windows, glazed panels, and the panels of the door themselves can all be upgraded to improve their thermal performance.
- 2.** The door should be repaired to ensure a good fit with its frame and the junction between the two upgraded with brush seal draught strips or similar.
- 3.** Don't forget to close other internal doors before you let heat out when leaving the building.
- 4.** A draught excluding letterbox flap and escutcheon to the key-hole will close easy routes for draughts to enter the home.
- 5.** A heavy curtain will reduce heat loss and limit draughts when the door is closed.
- 6.** A draught excluder is an effective way to prevent cold air entering through a door.



## TIMBER DOOR DRAUGHTPROOFING

### **What is it?**

External doors of a home are typically of simple construction, with slender panels in a door leaf which is set within a timber frame. This arrangement can be poor at containing heat. A more significant problem is draughts, particularly if there are gaps around the door that are poorly fitted, allowing warm air to escape and cold air to enter. In addition, letter boxes and keyholes can also provide a route for draughts. At the perimeter of a door leaf draught proofing should be fitted to close the gap when the door is closed. Simple mastic beads can improve the fit, and there are many proprietary brush seals and compression seals which are easily installed. Consideration should also be given to the junction between the frame and the wall, where mortars, mastics and seals may also need repair. Simple draughtproofing can be achieved with an excluder and thermal performance upgraded with a heavy curtain. An escutcheon to the keyhole, draught flap and brush seal to the letter box will also help.

Glazed panels and over door windows are also sometimes present and can contribute to the overall heat loss through a door. These can be upgraded as described for windows, described later in this chapter. Where possible, an internal lobby will greatly reduce heat loss when passing through the door. At the very least, consider closing doors to adjoining rooms before leaving the building.

### **How effective is it?**

The external doors of a building are as important to consider as any other element – as they typically account for up to 15% of the heat loss from a dwelling.

### **What does it cost?**

The majority of door upgrade techniques are DIY measures and are therefore good value. Mastic beads and proprietary draught strips are available very cheaply, as are draught-excluding letter flaps cost. The price of secondary glazing overdoor windows, glazed panels and upgrading the door panels themselves will depend on the complexity of the door.



## TIMBER DOOR DRAUGHTPROOFING

For **Heritage Asset** guidance on draughtproofing measures please refer to the [Draughtproofing Historic Buildings: Windows, Doors, Floors, Skirting Boards, Ceiling and Flues](#) page of this SPD.

### Further Guidance

[Centre for Sustainable Energy: DIY Draughtproofing](#)

# TIMBER FLOOR INSULATION

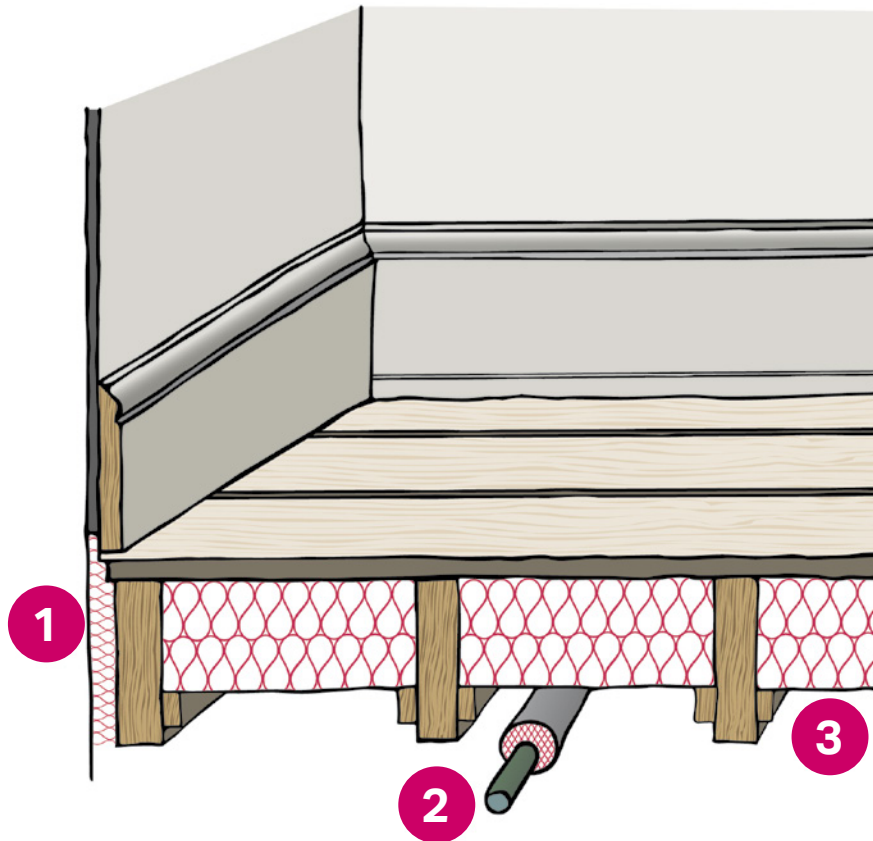

## Guidelines to maximise efficiency

1. It is important to insulate between the last joist and the wall as these narrower spaces are closest to the exterior and are therefore the coldest.
2. Ensure that building services which pass below the floor are also insulated.
3. Rigid insulation will need to be carefully trimmed to give a close fit and could be supported on timber battens secured to the joists. A compressible insulation such as mineral wool or sheep's wool will give a snug fit and can be supported on a lightweight net laid over the joists.

Ensure that any sub-floor ventilation and air bricks are not obstructed, and the insulation is at least 150mm clear of the ground level. In methane or radon affected areas seek advice from the LPA's building control department.

# TIMBER FLOOR INSULATION

## What is it?

Insulating timber floors will normally involve lifting some of the floorboards and laying insulation between the joists so as to improve the thermal performance of the most slender element i.e. the boards themselves

Typically, 60% of the energy used by dwelling is for space heating and around 15% of this is lost through the ground floor. Insulating a suspended timber floor within the joist depth (as indicated) can reduce this to below 5%. Overall, this can be 5-8% of your carbon emissions saved.

## What does it cost?

An average DIY installation will cost around £100 and can recover its cost within two years.

## Things to be aware of:

- Underneath the insulation, ventilation needs to be maintained. A structure may be required to achieve this.
- This intervention may require you to lift every floor board, which can be time-consuming and cause damage.
- Draught proofing is a complementary measure to Timber Floor Insulation (e.g. corking between panels).
- Sustainable materials, now widely available, should be utilised where possible e.g. sheep's wool fibre, natural fibre boards etc.
- Be careful to avoid cables during installation.

# TIMBER FLOOR INSULATION

## **Heritage Assets**

### **Is listed building consent required?**

Listed Building Consent **is not normally required**, unless original building elements would require temporary removal.

#### **Guidelines for heritage assets**

- Insulating suspended timber floors from below is usually preferable except where there is a historically significant surface to a ceiling below. Installation from above should only be considered where it is not possible to insulate from below.
- If installation from above is required, a professional will be required to avoid damaging historic building elements (e.g. floorboards, skirting boards, door architraves).
- Quilt or rigid board insulation is preferable – sprayed foams will not usually be acceptable as they are not easily reversible should future repairs be required.

- Breathable materials should be used to maintain the passage of air and moisture.
- If lifting floorboards reveals 'deafening' material, this should be left in place, as it can be an efficient fire retardant.

#### **Further Guidance:**

[Historic England Energy Efficiency and Historic Buildings: Insulation of suspended timber floors](#)

**Draught proofing is a complementary measure which can be used in conjunction with timber floor insulation. See pages 14,15,19,20,21 and 22 of this SPD for information on draughtproofing.**

## CHIMNEY REGISTER PLATE

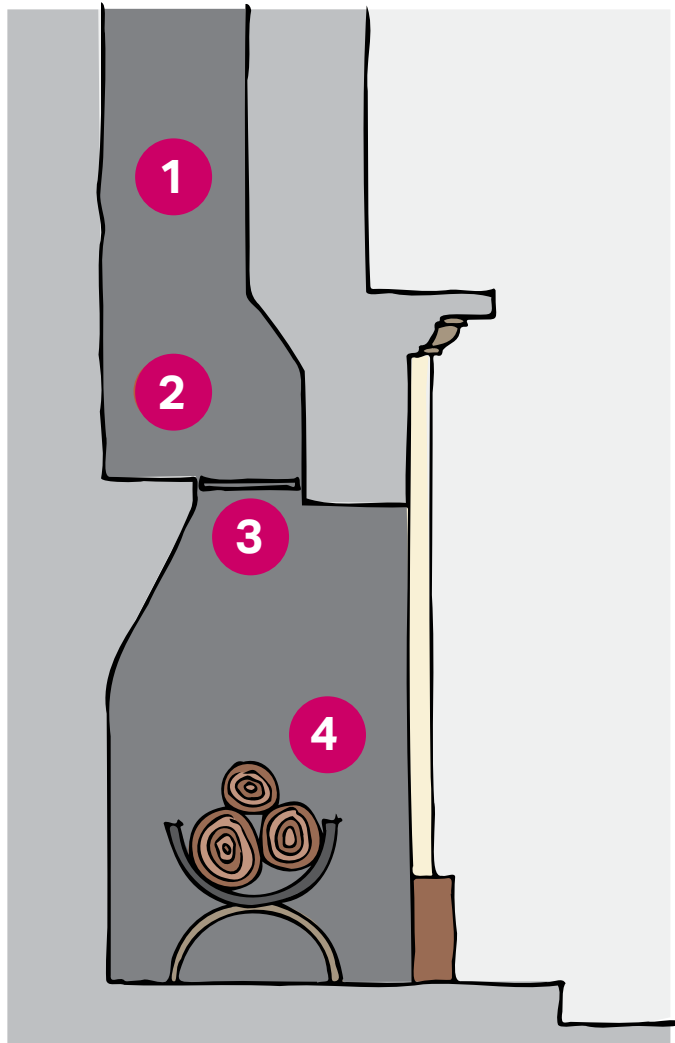

- 1.** The existing flue remains unaltered and capable of functioning normally when the register plate is opened.
- 2.** A register plate will need regular cleaning as soot, nesting material and other debris can accumulate on the upper surface and this may present a fire hazard if left.
- 3.** A register plate is normally made of steel, set within a simple frame. The frame is mechanically secured to the masonry of the chimney and its perimeter is usually sealed with fire cement or a rope gasket to produce a close fit. An opening 'flap-door' allows smoke to pass when the flue is in use and can be adjusted to provide different degrees of ventilation at other times.
- 4.** The open fireplace can remain as a feature in the room and without needing to be permanently closed it can easily be used when required

## CHIMNEY REGISTER PLATE

### What is it?

A register plate is a fireproof structure which is fitted in the lower part of a chimney and physically closes the flue to prevent draughts.

Many fireplaces in 19<sup>th</sup> and 20<sup>th</sup> century properties will already have integral chimney plates installed.

Unlike a chimney balloon, a register plate can remain in-situ when the fire is in use. A flap door contained in the plate is simply opened to allow smoke to escape when required. With a stay fitted, this flap door can also be adjusted to open varying degrees to aid ventilation as required.

In addition to use with open fires, a register plate may also be required where log burners, multi-fuel stoves and other biomass burners are inserted into an existing fireplace.

A register plate would normally be constructed of metal and specially fabricated to suit the size and shape of the particular flue.

For safety reasons advice should be sought from a suitably qualified person before inserting any structure that restricts the size of an operable flue.

A registered member of HETAS or the National Association of Chimney Sweeps (NACS) may be able to help.

### How effective is it?

In extreme cases, as much as 80% of the heat from a room can pass through a chimney flue; the insertion of a register plate will greatly reduce this figure.

By being adjustable a register plate can be effective year-round – simply open or close to control heat loss, draughts, and ventilation.

You must ensure that the flue is in a good state of repair and structurally sound.

It is sensible to undertake a smoke test at the same time as installation in order to ensure there is a proper draw and no leakages.

## CHIMNEY REGISTER PLATE

### What does it cost?

As a register plate is made to measure and requires permanent fitting, a little more work is required than for DIY measures. The cost will vary with the size and complexity of the flue.

### *Heritage Assets*

### Is listed building consent required?

Listed Building Consent **is not required** for chimney register plates.

### Guidelines for Heritage Assets:

- The chimney register plates should be carefully installed, ensuring no damage to the historic fabric.
- Ensure that the register plate has ventilation holes. Alternatively, the fireplace could be blocked by a panel at its opening with a vent inserted in the panel.

### Further Guidance:

[Historic England Energy Efficiency and Historic Buildings: Open Fires, Chimneys and Flues](#)

## CHIMNEY DRAUGHTPROOFING BALLOON

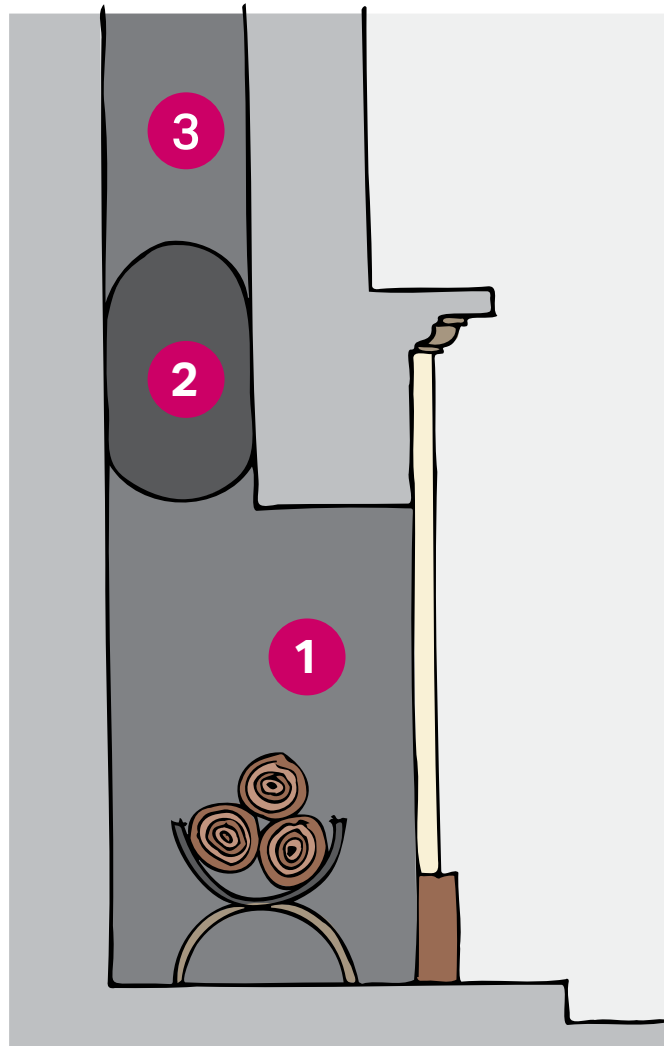

1. The open fireplace can remain as a feature in the room and without needing to be permanently closed it can easily be used when required.
2. A chimney balloon is a simple DIY installation fitted within easy reach at the foot of the flue. The air-bag adopts the shape of the flue as it is inflated and provides an air cell which acts as a thermal buffer to insulate against heat loss, as well as a physical barrier to reduce draughts.
3. The existing flue remains unaltered and capable of functioning normally when the chimney balloon is deflated.



## CHIMNEY DRAUGHTPROOFING BALLOON

### What is it?

Most older buildings and many modern ones contain a chimney or flue, serving a fireplace. All of these have an open throat at the hearth, connected to the outside by a narrow void or 'flue' that normally terminates at roof level. In an active fireplace the flue will be warmed by the fire and the thermal mass of the chimney will help dissipate heat around the home.

A used flue is unlikely to suffer from cold down-draughts unless it is not working properly but a fully functioning flue loses a significant portion of the heat produced by a fire directly to the outside. However, in an un-used fireplace the picture is different; the flue becomes a route by which cold air can enter the building and energy used for heating the home by central heating, for example, is wasted.

A chimney balloon is a simple and effective means to prevent draughts and reduce heat loss from un-used flues. It can also significantly reduce noise infiltration, which may be of benefit for properties in town centres or close to roads, rail and flight-paths.

The balloon consists of a simple plastic 'air-bag' which is placed inside the chimney flue and inflated by a foot pump or tube until it forms a snug fit with the sides of the chimney flue – forming an effective seal. Balloons are available in a range of standard sizes to suit the most commonly found flues but can also be made to measure for even the largest and most unusually shaped flues.

Balloons are simply fitted and fully reversible; they can easily be removed for cleaning or during the fairer summer months, when natural stack-effect ventilation through a chimney would reduce energy consumption from mechanical extract fans and air conditioning systems. Open chimney flues do aid natural ventilation and the removal of moisture and damp, so it is not always advantageous to block a flue permanently or completely.

You must ensure that the flue is structurally sound and in a good state of repair before installing the balloon.

# CHIMNEY DRAUGHTPROOFING BALLOON

## How effective is it?

As much as 80% of the heat from a room can pass through a chimney flue; the insertion of a chimney balloon will greatly reduce this figure. By being both adjustable and reversible a chimney balloon can be effective during the winter months and allow the flue to provide ventilation and cooling during the summer months.

## What does it cost?

Together with a valve, pump and re-usable air-bag a chimney balloon installation can cost less than £30. The effect on reducing energy consumption means this modest sum can easily be recovered in the first year.

## Heritage Assets

### Is listed building consent required?

Listed Building Consent **is not required** for Chimney Draughtproofing Balloons.

#### Guidelines for Heritage Assets:

The chimney register balloon should be carefully installed, ensuring no damage to the historic fabric.

#### Further Guidance:

[Centre for Sustainable Energy: DIY Draughtproofing](#)

[Historic England Energy Efficiency and Historic Buildings: Open Fires, Chimneys and Flues](#)

## METAL FRAMED WINDOW DRAUGHTPROOFING

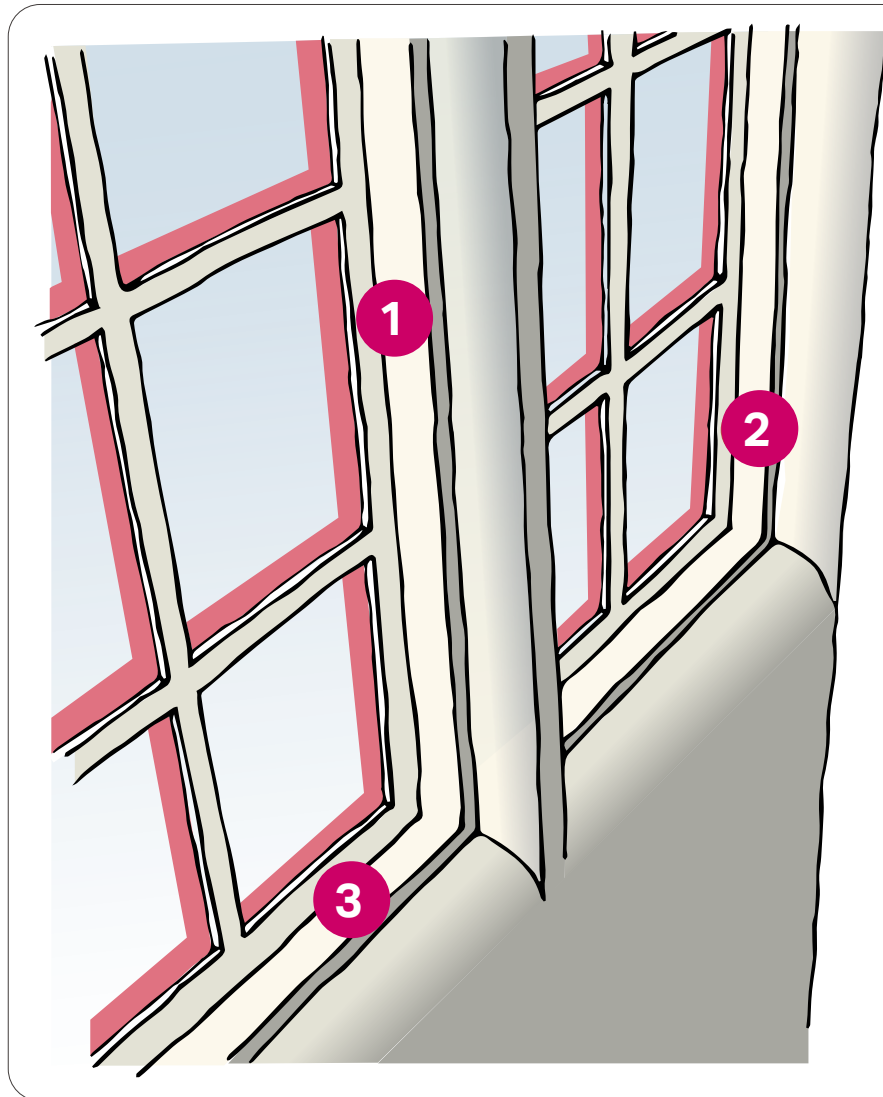

**1.** Proprietary compression and wiping seals are also available which can be discreetly fitted at the perimeter of the window.

**2.** A simple draughtproofing technique is to apply around the window where the faces meet the frame, with a release tape applied to the frame. This achieves a good fit, with minimal impact on the building fabric and can be applied when re-decorating.

**3.** The gap between a metal window and its frame or surround can account for a significant amount of the heat loss. Improving the fit of the window by keeping it in good repair will help and draughtproofing will ensure the energy lost is kept to a minimum.

## METAL FRAMED WINDOW DRAUGHTPROOFING

### **What is it?**

Most traditional metal framed windows are single glazed with large plain glass panels, or in the case of earlier windows, with multiple small panes held in lead. Later windows often have a metal sub-frame, but early windows may be simply set in rebates against stone or timber surrounds. In either case, the closeness of fit between the opening parts of the window and their frame or surround will greatly affect the performance of the window by allowing draughts to enter and heat to leave the building. In addition to placing the window in good repair, simple draughtproofing techniques can be used to improve the situation. A simple technique such as release tape and a mastic bead can be part of the routine decoration of the window. Compressible and wiping seals are also commonly available which sit discretely at the junction between frame and window.

### **How effective is it?**

As much as 80% of the heat lost through a single glazed window can be through air-leakage or 'draughts' and addressing this makes good sense.

As a conductive material, metal windows will always facilitate greater loss of heat compared to other non-conductive materials.

### **What does it cost?**

The simplest draughtproofing measures are DIY level installations and are therefore quite inexpensive. A mastic and tape decoration upgrade can be installed for less than £5. Proprietary weather seals are available which vary in cost between simple self-adhesive profiles for less than £1/Metre to those with profiled and replaceable seals for a little more. If DIY fitted, the cost will be modest and likely less than £20 per window.

## METAL FRAMED WINDOW DRAUGHTPROOFING

### Potential issues to be aware of

Before work, you should check for the following and correct before implementing this measure:

- Surface rust;
- If the windows are too badly distorted, secondary glazing should be used instead of draughtproofing;
- Ill-fitting windows including damaged hinges;
- Excessive paint build up which can cause closing problems.

For specific **Heritage Asset** guidance on draughtproofing measures please refer to the [Draughtproofing Historic Buildings: Windows, Doors, Floors, Skirting Boards, Ceiling and Flues](#) page of this SPD.

### Further Guidance:

[Centre for Sustainable Energy: DIY Draughtproofing](#)

## TIMBER CASEMENT WINDOW DRAUGHTPROOFING

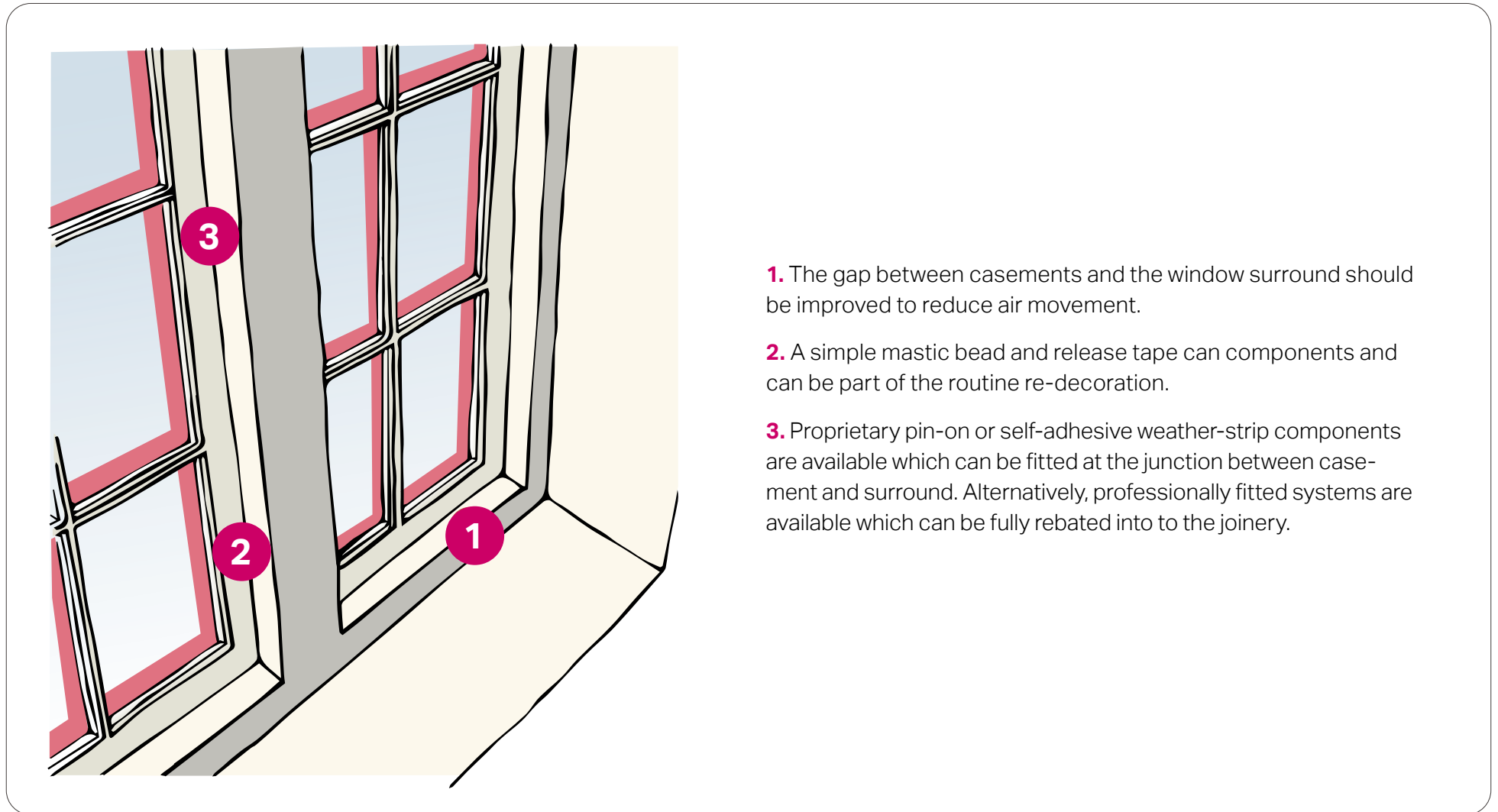

## TIMBER CASEMENT WINDOW DRAUGHTPROOFING

### What is it?

Timber casement windows typically have opening frames which sit within a timber surround, when closed. Normally hinged to one side, these frames are designed to be a close fit with the surround to keep weather out, but a gap has to exist to allow the window to open.

Over time and through wear this gap can increase in size. Warm air can be lost from the building through this gap and cold air can enter. In addition to ensuring that the window is well maintained, simple upgrade techniques can be used to improve the situation. A simple mastic bead and release tape will do much to improve the fit between window components and can be installed as part of the routine decoration of the window. Proprietary 'draught-strip' components are also available to provide a combination of compression seals and wiping seals to effectively close the air path at the perimeter of a casement window.

### How effective is it?

A significant amount of the heat lost through a casement window can be through air-leakage or 'draughts' – so addressing this makes good sense. Recent research has shown that placing the window in good repair can reduce air leakage by a third and draughtproofing will substantially improve on this. When combined with other measures, such as secondary glazing, blinds or heavy curtains the benefit from simple draughtproofing can be considerable.

Windows need to be in a good state of repair before any work is carried out.

## TIMBER CASEMENT WINDOW DRAUGHTPROOFING

### What does it cost?

The simplest draughtproofing measures are DIY level installations and are therefore quite inexpensive. A mastic and tape decoration upgrade can be installed for less than £5.

Proprietary weather seals are available which vary in cost between simple self-adhesive profiles for less than £1/Metre, to pin-on, surface-fixed brush seals for around £2-3/Metre. Professionally fitted systems are also available, which although considerably more costly will normally be fitted as part of a comprehensive window overhaul.

For specific **Heritage Asset** guidance on draughtproofing measures please refer to the [Draughtproofing Historic Buildings: Windows, Doors, Floors, Skirting Boards, Ceiling and Flues](#) page of this SPD.

### Further Guidance:

[Centre for Sustainable Energy: DIY Draughtproofing](#)



## TIMBER SASH WINDOW DRAUGHTPROOFING

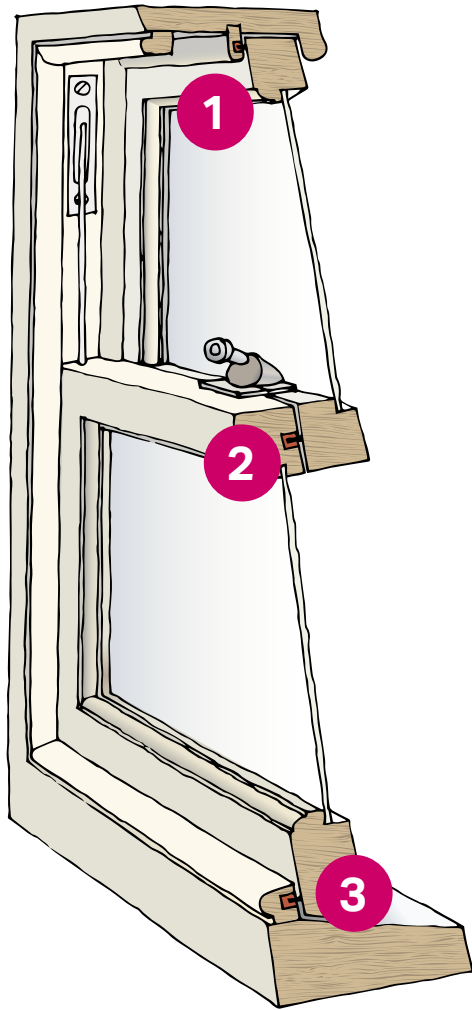

- 1.** Staff bead and parting-bead can be replaced with components incorporating brush seals for draughtproofing (although note this is not the case with traditional/historic building fabric).
- 2.** The gap between the upper and lower sash can be improved with the addition of a mastic bead or brush seal. Draughtproofing will need to be applied around the whole sash and may also be needed for the gaps where the wheels are.
- 3.** Proprietary systems are available which are rebated into the joinery and are almost invisible when fitted. Where there are original windows, the secondary glazing should match the opening pattern e.g. meeting rail position should be matched.

## TIMBER SASH WINDOW DRAUGHTPROOFING

### **What is it?**

These windows normally have glazed timber sashes (frames) set within box profile outer frames that contain counter-weights to allow the window to slide vertically. Unlike casement windows which close against the frame, these windows rely on a gap between the perimeter of the sash and the frame to provide sufficient room to be able to open. This means that a sliding sash window has a feature of its design which introduces a route for air movement. As the windows age and components wear, this gap can become enlarged, allowing cold air to enter and warm air to leave the building.

In addition to placing the window in good repair, simple draughtproofing techniques can be used to improve the situation. A simple technique such as release tape and a mastic bead can be part of the routine decoration of the window. Proprietary systems are also available that replace the beads with ones containing brush seals which can significantly reduce air infiltration. Additionally, compression seals can be rebated into the joinery at the head of the top sash and foot of

the lower one and wiping seals can be rebated into to the junction between the two.

### **How effective is it?**

A significant amount of the heat lost through a single glazed window can be through air leakage or 'draughts' – so addressing this makes good sense. It can be possible to raise the performance of a sash window to a level equivalent to modern double-glazed replacements by combining draughtproofing with shutters, blinds and heavy curtains. With such measures it is possible to raise the performance of a sash window to a level above many modern double-glazed replacements.

Ensure that windows are in a good state of repair before any work is undertaken.

### **What does it cost?**

The simplest draughtproofing measures are DIY level installations and are therefore quite inexpensive. A mastic and tape decoration upgrade can be installed

## TIMBER SASH WINDOW DRAUGHTPROOFING

for less than £5. Proprietary weather seals are available which vary in cost between simple self-adhesive profiles for less than £1/Metre, pin-on, surface-fixed brush seals for £2-3/Metre; through to professionally fitted systems which replace beads and rebate seals into the sash joinery.

These professionally fitted systems can cost considerably more, but often include overhaul of the entire window. A simple mastic bead and release tape can improve the fit between the head of the upper sash and the frame. This can also be used at the foot of the lower sash. Alternatively, proprietary compression seals are available. Some of these can be fully rebated into to the joinery.

For specific **Heritage Asset** guidance on draught-proofing measures please refer to the [Draughtproofing Historic Buildings: Windows, Doors, Floors, Skirting Boards, Ceiling and Flues](#) page of this SPD.

### Further Guidance:

[Centre for Sustainable Energy Draughtproofing Leaflet](#)

# DRAUGHTPROOFING HISTORIC BUILDINGS: WINDOW, DOORS, FLOORS, SKIRTING BOARDS, CEILING AND FLUES

## Is listed building consent required?

Listed Building Consent **is not normally required**, unless the appearance of the room would be significantly affected.

For background information on what these measures are, their effectiveness, and cost, including guidelines for non-traditional buildings, refer to the following pages within this SPD:

- **Timber Floor Draughtproofing**
- **Timber Door Draughtproofing**
- **Chimney Draughtproofing Balloon**
- **Metal Framed Window Draughtproofing**
- **Timber Casement Window Draughtproofing**
- **Timber Sash Window Draughtproofing**

## Guidelines for Heritage Assets: Draughtproofing Skirting Boards, Ceilings and Flues:

- Any mastic-type draught proofing should be as discreet as possible in colour (i.e. clear, or matching the surrounding colour as closely as possible)
- Skirting boards: Care should be taken if temporary removal of skirting boards is required.
- Flues: temporarily sealing of unused flues is also a simple process that does not require consent – chimney balloons are simple to fit and are removable. Typically, they also permit some air flow through being ill-fitting, which is important for ventilation. Total sealing of flues is not recommended.

## DRAUGHTPROOFING HISTORIC BUILDINGS: WINDOW, DOORS, FLOORS, SKIRTING BOARDS, CEILING AND FLUES

### Guidelines for Heritage Assets: Draughtproofing Floors and Doors:

- Floors: Sealing the gaps between floorboards, traditionally referred to as caulking, is the most likely of these measures to affect appearance and can make them harder to lift in the future. If you are planning any associated works that may require lifting of floorboards these should be done before sealing these gaps. Proprietary flexible caulking strip is an inexpensive and simple measure for draught proofing the gaps between timber floorboards. It should be noted that comprehensive eradication of natural ventilation beneath timber floors can lead to damp and decay.
- Unobtrusive products should always be used and loss of historic fabric avoided.
- Non-permanent solutions should be favoured where possible (e.g. laying a rug or another breathable membrane on the floor).

- Professional installation will be needed for products such as rebated edge seals
- Care should be taken to ensure the strength of the frame is not compromised. This is particularly the case with slender late 18<sup>th</sup> century sash windows where the timber sections are often very narrow.

### Further Guidance:

[Historic England: Draughtproofing Windows and Doors](#)

[Historic England: Draughtproofing Older Buildings](#)

## SECONDARY GLAZING

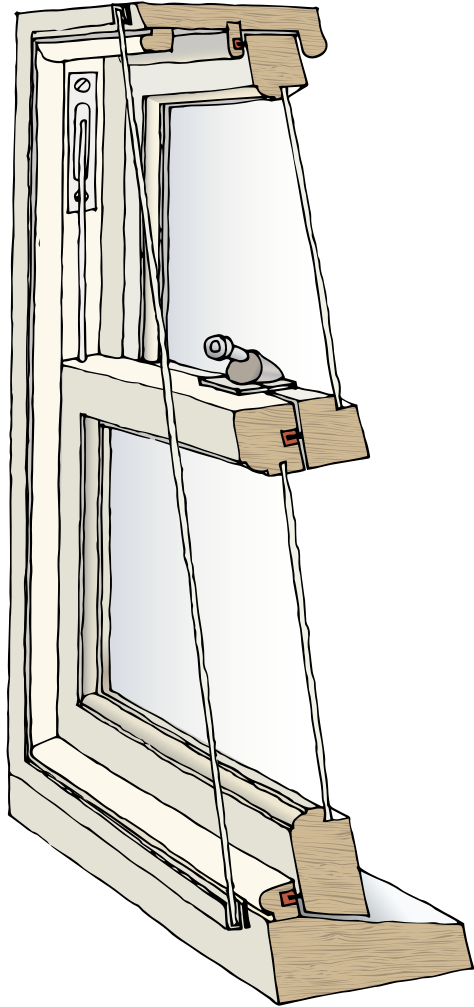

Secondary glazing in metal framed windows, St Alpheges Presbytery, Bath.  
Photo copyright: Bath Preservation Trust.

## SECONDARY GLAZING

### What is it?

Secondary glazing units are normally single glazed, glass or lightweight polycarbonate sheet.

The simplest systems are single pane panels which can be secured with magnetic tape, making them easy and quick to fit and reducing 'retrofitting' work to a minimum.

The perimeter frames are narrow, so remain unobtrusive, and some can accommodate double-glazed units if space permits. Slender profile double glazing can be a good solution and will help raising an existing window toward triple-glazed performance levels without loss of the existing window.

In addition to the enhanced thermal performance, secondary glazing can also eliminate draughts and improve acoustic privacy.

While there are many types of secondary glazing, it is recommended to install those which do not require a sub-frame, enabling the retention of the original window appearance. It is also recommended that

the chosen materials are recycled, or recyclable, for sustainability.

You can have seasonable secondary glazing systems that are removable.

### How effective is it?

The addition of secondary glazing to a traditional double hung sliding sash window can reduce heat losses by 58%.

If measured and fitted correctly, and when combined with timber shutters and heavy curtains, the energy saved in cold weather can be as good as double glazing.

### How much does it cost?

The cost will depend on a number of variables. A typical installation, with two single glazed low-e glass panels, the lower panel of which is sliding, costs in the region of £400 for a 1.8x1.2m window.



## SECONDARY GLAZING

### **Heritage Assets**

#### **Is listed building consent required?**

Listed Building Consent **is normally required** for secondary glazing.

#### **Guidelines for heritage assets:**

- Ensure that the design is as discreet as possible and does not obscure distinctive architectural detailing, including careful alignment of any glazing bars and use of slim frames of appropriate colour. With terraced dwellings, the design should retain a sense of unity with surrounding properties.
- Ensure that they will not compromise the use of existing shutters
- Minimise the impact of permanent fixings required to secure the new frame
- Consider fitting secondary glazing within an easily-removable frame that does not require a separate subframe and will allow the use of the existing windows and, where they exist, shutters.

- The secondary glazing units can be colour-finished to match the existing interior decorative scheme.
- In many circumstances magnetic strip secondary glazing is likely to be consented.

#### **Further Guidance:**

[Historic England Energy Efficiency and Historic Buildings: Secondary Glazing for Windows](#)

[Historic England: Traditional Windows: their care, repair and upgrading](#)

[Historic England's Library of guidance for altering windows](#)

[Historic England: Modifying historic windows as part of retrofitting energy saving measures](#)

- Draught proofing is a complementary measure which can be used in conjunction with secondary glazing. See pages **14, 15, 19, 20, 21** and **22** of this SPD for information on draughtproofing.



## SLIM PROFILE DOUBLE GLAZING

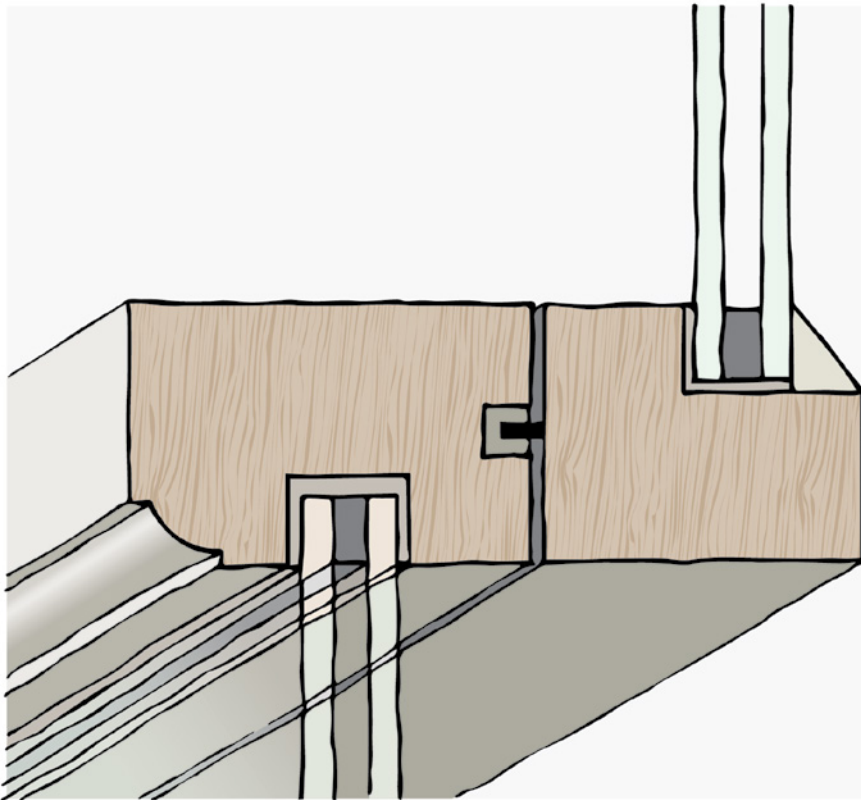

Replacement slimline (12mm) double-glazed sash windows alongside existing original single-glazed windows in Arlington House, Stall Street, Bath.

# SLIM PROFILE DOUBLE GLAZING

## What is it?

Slim-profile double glazing is a method by which the thermal performance of a older window can be improved with a narrow double-glazed panel.

These panels use thin glass with a slim cavity that is normally filled with an inert gas, to improve its resistance to the passage of heat.

If the rebate is sufficiently deep, the panels can be putty fixed to match the original glass. The perimeter spacer used to separate the glass sheets can be colour matched to the joinery and the final appearance hard to detect.

## What does it cost?

The cost of slim profile double glazing varies considerably according to the materials used for the frame, type of window (e.g. sash), and gas used for the performance of the glazing units. Quotes need to be obtained to accurately compare.

## Heritage Assets

### Is listed building consent required?

Listed Building Consent **is required** for installation of new double-glazed windows.

### Top tip for heritage assets:

Narrow profile double glazing is available using traditional cylinder glass on the outer pane; this is encouraged as it would enhance the traditional appearance of the building.

### Guidance position

The LPA supports, where possible, the careful replacement of windows with timber-framed, slim-profile double-glazed units. Some examples of where this intervention may be considered acceptable would be where:

- the existing windows are agreed as being modern or of no historic significance or heritage value
- the existing windows are original or historic, but are beyond feasible repair

## SLIM PROFILE DOUBLE GLAZING

- replacement would enhance the special architectural or historic interest of the building - for example where existing windows are inappropriate modern replacements and new windows are correctly and authentically detailed and constructed resulting in a significant heritage gain.

This would be assessed on a case-by-case basis, so do not be deterred from seeking further advice on your property to find out if slimline double glazing could be appropriate.

### Guidelines for Heritage Assets:

- The section of the glazed units should be no greater than 12mm (two layers of glass + cavity)
- The thickness and profile of timber glazing bars should try to replicate the original glazing bars, avoiding applied (i.e. false) glazing bars or lead comes.
- uPVC is not regarded as an appropriate material for heritage assets and is not sustainable.
- When selecting the glazing, try to limit the change in appearance of the glass with regard to colour or reflectivity as much as possible.
- The colour of any spacer (the perimeter strip between the two panes of glass) should match the colour of the painted timber.

- Existing historic windows should be repaired and retained, and in the majority of cases this will be possible. Retrofitting any form of double glazing into an historic window is unlikely to be feasible or appropriate. However, consideration could be given to the use of energy efficient single glazing; this is now readily-available and is likely to be suitable for installation into an historic window. This may increase the weight of sash windows and some adjustment of the counter-weights may be required, but should not result in the discarding of the historic weights. As with narrow profile double glazing, traditional cylinder glass could be used and is available as a product.

#### Further Guidance:

[Historic England: Traditional Windows: their care, repair and upgrading](#)

[Historic England's Library of guidance for altering windows](#)

[Historic England: Modifying historic windows as part of retrofitting energy saving measures](#)

## DOUBLE AND TRIPLE GLAZING

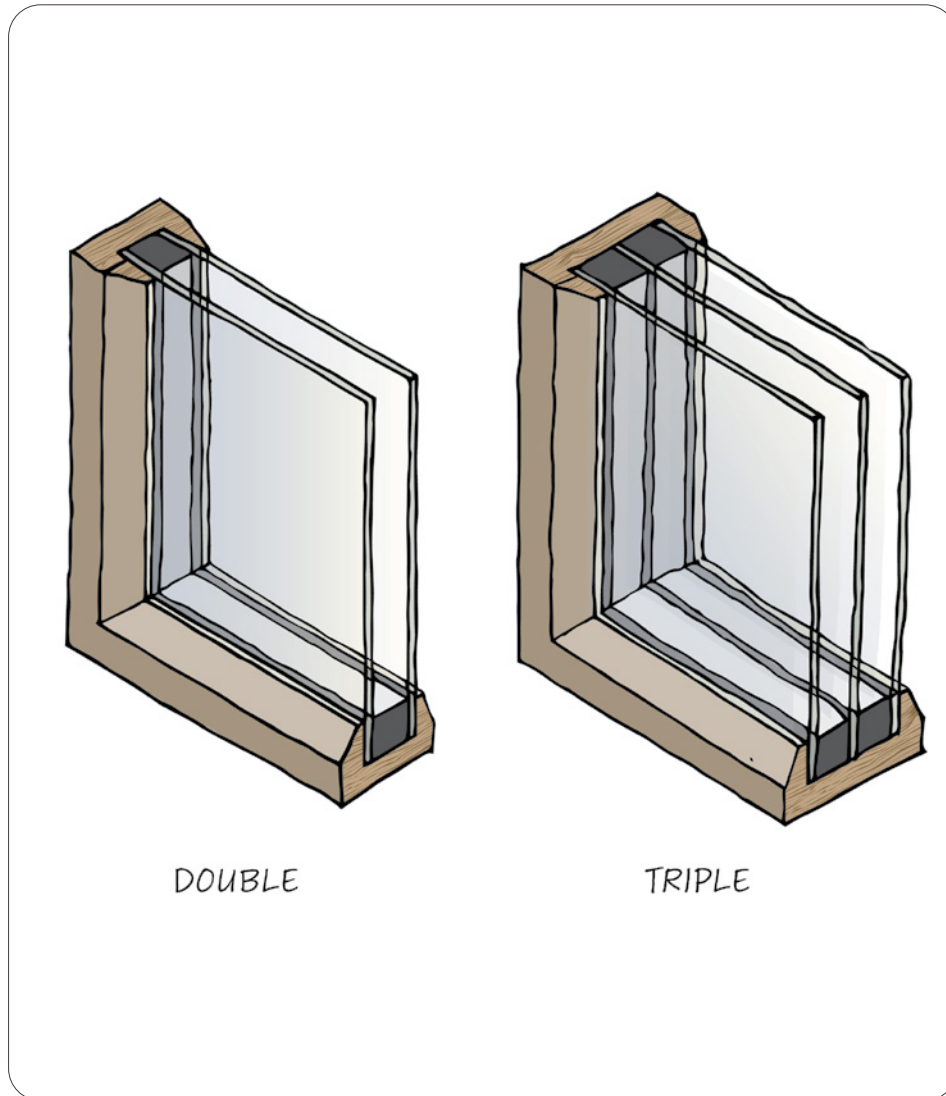

### What is it?

Single-glazed windows can let as much as 60% of the heat escape from your home; this is detrimental in terms of the cost of your heating and the cost to the planet.

Double or triple glazing is formed by two or three window panes separated by a gap filled with air or another gas such as Argon to create an insulating barrier limiting heat transfer through windows. The panes are separated with spacers that should be designed to prevent heat loss and condensation. Triple-glazing is optimal in terms of efficiency because it further insulates the building: the more layers of glass the window has, the less heat loss there is.

## DOUBLE AND TRIPLE GLAZING

### How effective is it?

To maximize the insulating effect of double and triple glazing, the optimum gap required between the panes of glass is about 12-16mm. Too close together results in radiant heat loss; too far apart leads to creation of gas currents which causes convection current heat losses.

A window's thermal transmittance, or how effectively it stops heat escaping, can be expressed as a U-value. Simply put, the higher the U-value, the more heat a window loses. Typically, the U-values (measured in  $W/m^2K$ ) of different window glazing options can be around:

- Single glazing = 5-5.6
- Double glazing (with air cavity) = 2.8
- Double glazing (with argon gas cavity) = 2.6
- Double glazing with low emissivity glass (with air cavity) = 1.8
- Double glazing with low emissivity glass (with argon gas cavity) = 1.5
- Triple glazing = 0.7-1.6

As such, when compared to single-glazed windows, both double and triple glazing are highly effective retrofitting measures in terms of energy efficiency and potential energy saving cost.

### What does it cost?

It pays to shop around for quotes. Prices will vary significantly based on a number of factors, including:

- The materials used. Most notably, whether the windows are uPVC (which are the least expensive option) or wooden (which are more expensive);
- How many windows you want to get replaced;
- The size of your windows;
- How many openers they have;
- The materials used;
- Any special glazing process – for example, tinted glass;
- Whether your old windows can be recycled – as some companies will take them away for recycling and then give you a discount!

## DOUBLE AND TRIPLE GLAZING

### How to find reliable double and triple glazing companies:

There are several ways of finding reliable installers for your double or triple glazing. One way is to check out websites of regulatory bodies like [FENSA](#) and [Certass](#). They can also give you a list of local certified installers and suppliers.

### Heritage Assets:

#### Is listed building consent required?

Listed Building Consent **is required** for installation of new double-glazed windows.

#### Guidelines for Heritage Assets:

- As an alternative to double glazing, in cases involving heritage assets, the LPA suggests, where appropriate, the use of slim profile double glazing or secondary glazing (see the **Slim Profile Double Glazing** and **Secondary Glazing** SPD pages). If measured and fitted properly, and combined with

timber shutters and heavy curtains, the energy saved in cold weather can be nearly as good as standard double glazing units.

- The LPA is unlikely to support the use of standard width double-glazed units or triple-glazed units in listed buildings other than on existing or proposed modern extensions. This is because they are not regarded consistent with the traditional character and appearance of listed buildings, and would likely conflict with the requirement to preserve their special architectural or historic interest of the building.

#### Further Guidance:

[Historic England: Traditional Windows: their care, repair and upgrading](#)



# REINSTATING MISSING SHUTTERS IN HISTORIC BUILDINGS

## What is it?

Window shutters are usually an internal feature, but there are exceptions.

About 30% of a home's heating energy is lost through windows. By reinstating shutters in homes where they have been removed, this help to insulate buildings, thereby reducing heat loss.

## How effective is it?

Research shows that the use of shutters offers a significant improvement in thermal performance by preventing heat loss.

When the shutter panels and louvres are closed, they can reduce heat loss through a window by more than 50%. Combined with secondary glazing, this can exceed 62%.



Existing shutters at Somerset Place, Bath



# REINSTATING MISSING SHUTTERS IN HISTORIC BUILDINGS

## What does it cost?

The average cost of installing window shutters will vary depending on the material, style, size and function. On average, it will usually cost between £500-£1200.

## **Heritage Assets:**

### Is listed building consent required?

- Listed Building Consent **is required** and replacements should be of the correct style, material and detailing to the originals.
- Where shutters survive but have been painted, nailed or screwed shut, releasing them **does not require** Listed Building Consent.

## Guidance position

The LPA supports careful reinstatement of shutters where there is clear evidence of them having previously existed.

## Guidelines for Heritage Assets:

- Professional installation of replacement shutters is strongly advised.
- Replacement shutters should be sympathetic to the design and materials of the window and replicate the original
- Releasing existing shutters may require the services of a suitably experienced and qualified professional depending on their condition and the ease of releasing them.
- Be aware you don't disrupt original ironmongery.
- Shutters can conflict with secondary glazing and usually cannot work together.

## Further Guidance:

[Historic England's Guidance for Traditional Windows](#)

## CAVITY WALL INSULATION

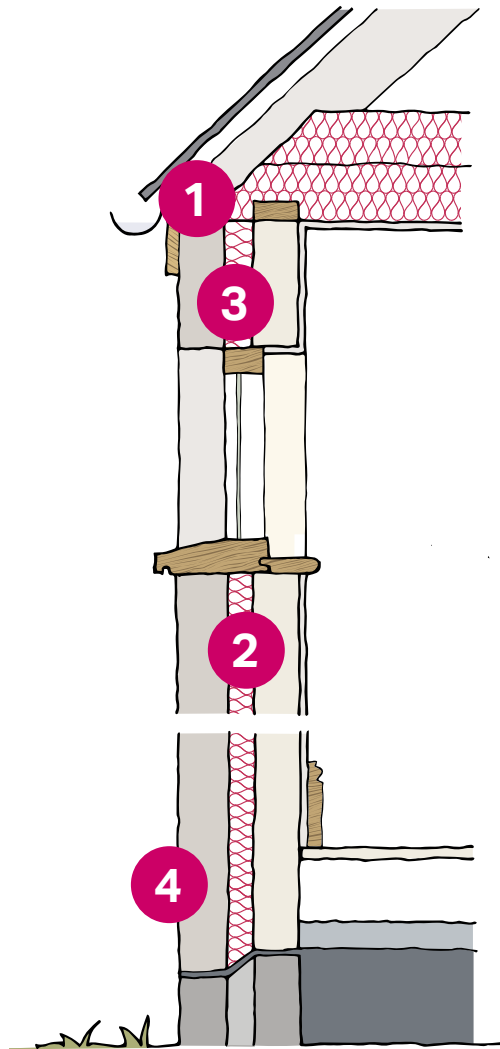

**1.** The edges of cavities at the roof and openings may need physical closers installed to ensure the insulation does not escape. The insulation should be weatherproof and water-repellent. Make sure to avoid sagging and slumping

**2.** Typically, fibre insulation or expanded polystyrene spheres are injected into the cavity through a series of entry holes drilled in the facade. The cavity is fully filled.

**3.** Some additional insulation measures may be needed around lintels, vents and other features which bridge the cavity.

**4.** Cavity wall insulation should be carried over the abutment with other insulation measures at the head and foot of the wall, to ensure there are no cold spots on the exterior at the floor and roof.

## CAVITY WALL INSULATION

### What is it?

The majority of buildings constructed in the 20<sup>th</sup> Century have external walls constructed of two layers, the outer being a weathering skin and the inner one usually structural. Space between the layers is a cavity used to drain any moisture which passes through the outer layer – preventing it from reaching the inside. These 'cavity' walls are usually quite thin and being made of slender components normally have low thermal performance.

Cavity wall insulation is a method of improving the building envelope by insulating the void between the skins of a cavity wall. A number of methods are available which involve an insulant being injected into the void. These insulants vary in their thermal efficiency, moisture resistance and integrity (ability to support themselves). The more commonly used insulation types are expanded polystyrene spheres and blown fibres.

The insulation is normally fitted over 1-2 days with holes drilled at intervals on the facade to allow the

insulation to be injected. Particular care must be taken at openings, perimeter of the cavities, ventilation routes and damp-courses to ensure the building can function as designed. A detailed survey will need to be undertaken by the installer to assess the suitability of the building for the insulation type being proposed.

Some highly exposed walls may not be suitable for cavity wall insulation. In later modern homes the cavity may already be partially filled with an insulation board and here retrofitting top-up insulation can be difficult as the void can be quite narrow. This insulation can be fitted without disruption, making it a suitable choice for many.

# CAVITY WALL INSULATION

## How effective is it?

The external walls of any building are normally the largest proportion of its envelope and so offer the greatest potential for heat loss. This element is therefore very important to improve. The effectiveness of the insulation will vary with the type of insulation chosen, size of cavity and proportion of wall to say windows, roof, etc. For most, an improvement in wall performance will of around 35% will be possible.

Use recycled materials where possible.

## What does it cost?

This cost will vary with the type of insulation, thickness of cavity and complexity of building – e.g. amount of scaffold required. Typical payback periods for cavity wall insulation are medium term, between 5-8 years. Some grants and financial assistance are available. Refer to The Energy Savings Trust, your utility company or the LPA for more information.

## Heritage Assets

### Is listed building consent required?

Listed Building Consent **is required** for cavity wall insulation within heritage assets.

#### Guidelines for Heritage Assets:

Pre-1920 houses are more likely to have solid walls. A solid wall has no cavity; each wall is a single solid wall, usually made of brick or stone. Therefore, it is unlikely that cavity wall insulation is a relevant retrofitting measure for consideration in most heritage assets or buildings of a traditional construction. Where this is not the case, please refer to the further guidance below from Historic England on Insulating Early Cavity Walls or contact the LPA for more information.

#### Further Guidance:

[Historic England: Insulating Cavity Walls](#)

[Centre for Sustainable Energy: Cavity Wall Insulation](#)

# INTERNALLY APPLIED SOLID WALL INSULATION (IWI)

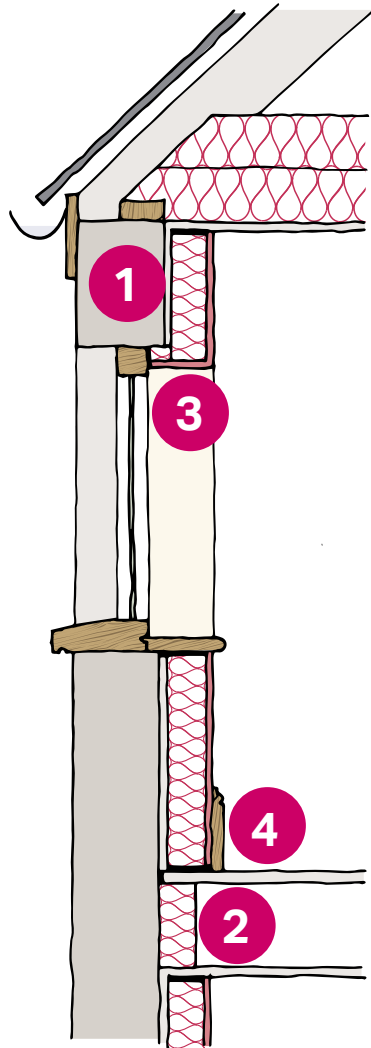

1. The insulation should be carried over lintels and the like and arranged so as to be contiguous with insulation at ground and roof level.
2. On terraced buildings insulation may be carried partly across the party walls to reduce the thermal bridging at the edges of the building.
3. Insulation should be carried into the floor voids to ensure continuity.
4. Insulation is carried into the reveals of windows and doors to ensure there are not cold spots where the wall is thinnest.

Insulation may require adjustment of building features such as skirting boards and redecoration.

## INTERNALLY APPLIED SOLID WALL INSULATION (IWI)

### **How effective is it?**

For most buildings, thermal performance of walls will be improved by around 35%.

### **What does it cost?**

This cost will vary with the type of insulation, thickness and complexity of building – typically a two-storey mid-terrace dwelling will cost £6-8k. Some grants and financial assistance are available. Refer to The Energy Savings Trust, your utility company or the LPA for more information.

### **Potential issues to be aware of:**

- Buildings with a solid wall construction rely on the transference of moisture from within the wall so that it can be dissipated as vapour. Internally, this process relies on adequate ventilation, otherwise insulation is likely to cause harm to internal fabric due to the increase in levels of damp and interstitial condensation between the existing internal wall surface and the internal surface of the wall insulation will occur.
- A desire is generally expressed for natural breathable insulants, such as hemp fibre, wool and cellulose, however other systems are available. Breathable paints and decorative treatments (including wallpaper) must also be used to ensure that moisture can continue to dissipate through the insulation.
- Cement-based insulating products are discouraged.

# INTERNALLY APPLIED SOLID WALL INSULATION (IWI)

## Heritage Assets

### Is listed building consent required?

Listed Building Consent **is required** for internal wall insulation.

#### Guidelines for Heritage Assets:

In many listed buildings and other historic buildings there is unlikely to be many opportunities for the installation of internal wall insulation and an alternative may be the use of an insulating lime plaster. However the following should be considered:

- A low-impact approach and discreet materials should always be considered in relation to the way they are installed or the depth of the insulating material
- Permeable insulation materials should always be used to allow moisture transfer through the walls. Features such as cornicing must be preserved – this may require the use of specialist insulation materials (e.g. slim-profile insulation, or blown

beads behind lath and plaster) that avoid obscuring the cornicing.

- Installation should be thorough (i.e. not leave gaps) to avoid cold bridging as far as possible.
- Permanent removal of historic architectural features such as skirting boards and architraves and other features is not regarded as acceptable however temporary removal may be required in some cases and care should be taken when removing and re-fitting them to avoid unacceptable harm. This should be undertaken by a trained professional.

#### Further Guidance:

[Historic England Energy Efficiency and Historic Buildings: Insulating Solid Walls](#)





# EXTERNALLY APPLIED SOLID WALL INSULATION (EWI)

## What does it cost?

This may be a more expensive solution than internal wall insulation, although it may be less disruptive for occupants. Other housing types, such as terraces, may differ.

You should also consider the additional costs of complex designs around existing doors, windows and roofs.

The type and quality of finish you use (e.g. rendering, boarding) will also largely determine the overall cost.

## Potential issues to be aware of:

- Buildings with a solid wall construction rely on the transference of moisture from within the wall so that it can be dissipated as vapour. This process relies on adequate ventilation, otherwise insulation is likely to cause harm to fabric due to the increase in levels of damp and interstitial condensation between the existing wall surfaces. With EWI, there is also a risk of cold bridging for attached neighbouring properties if their walls haven't also been insulated.

- A desire is expressed for natural breathable insulants, such as hemp fibre, wool and cellulose. Breathable paints and decorative treatments (including wallpaper) must also be used to ensure that moisture can dissipate. Cement-based insulating products are discouraged. If applying lime render, you must first remove painting in order for it to adhere.

## Heritage Assets

### Is listed building consent required?

Listed Building Consent **is required** for external wall insulation.

This measure is more likely to be considered acceptable on less-visible building facades compared to principle elevations.

# EXTERNALLY APPLIED SOLID WALL INSULATION (EWI)

## Guidelines for Heritage Assets:

- Vapour permeable insulation materials should always be used to allow moisture transfer through the walls.
- Where painting is proposed, permeable paints should be used (e.g. limewash or mineral paint) to retain the permeability of the insulating material and to achieve an appropriate finish and presentation of the building.
- Lime render is most appropriate for historic buildings.
- Great care is necessary to ensure that detailing at roof eaves, and window and door reveals does not adversely affect the building's appearance or ability to shed rainwater.
- If there is any evidence of damp, or repair, within the walls, this must be resolved before applying insulation. This may not be possible if there are external details which could be covered up, such as string courses.

## Further Guidance:

[Historic England Energy Efficiency and Historic Buildings: Insulating Solid Walls](#)

# INSULATING SOLID FLOORS

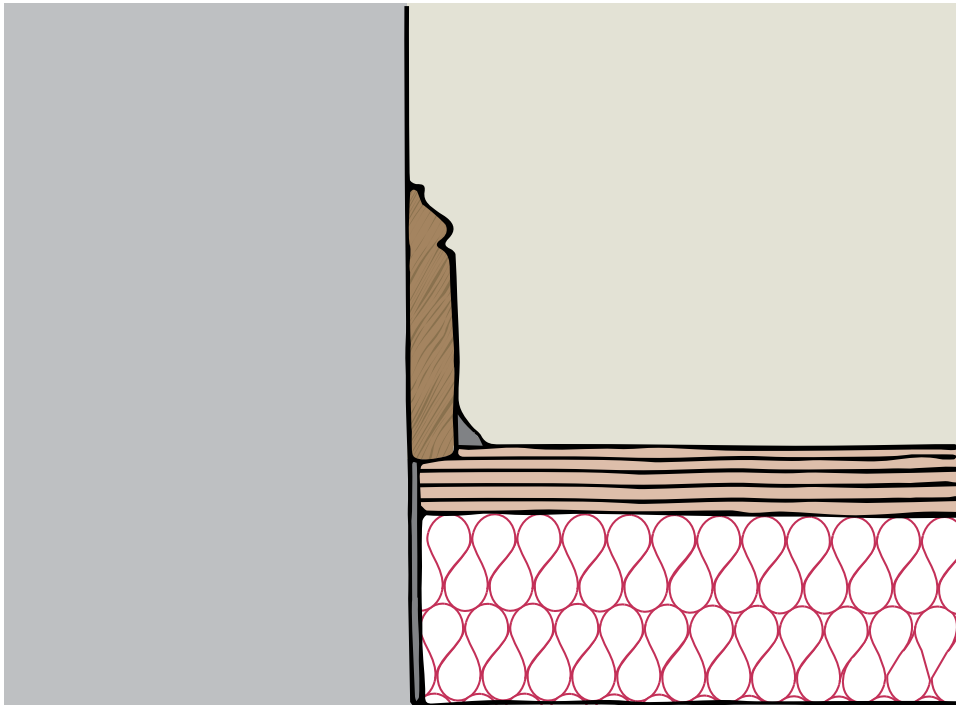

Illustration showing a cross section of solid floor insulation.



Photo showing insulation with integrated underfloor heating retrofitted to an existing solid floor.

## INSULATING SOLID FLOORS

### What is it?

Solid floors, such as concrete, generally lose less heat than suspended floors. They can still be insulated by laying a new layer of rigid insulation on top. This is then usually covered by chipboard and your desired floor covering. The insulation can be placed directly above the existing concrete or screed in the form of a 'floating' floor. This method will raise the floor level, so skirting boards may need to be refitted and doors will need to be trimmed. It may also be necessary to adapt thresholds.

### How effective is it?

In a typical dwelling 60% of the energy used is for space heating and a large amount of this can be lost through floors. Whilst the actual amount of heat lost through a solid floor is less than for modern suspended floors, still there are potential significant energy savings to be gained from insulating solid flooring.

### What does it cost?

The cost of solid floor insulation can range considerably depending on the size of your home and the retailer you purchase it from.

### Potential Issues to be aware of:

The most significant risk is that of creating condensation which can be on the surface of a building component or between layers of the building fabric, which is referred to as 'interstitial condensation'. This will occur if the solid floor insulation interferes with adequate building ventilation. To avoid this, ensure the risk is assessed in advance and installation is undertaken by a suitably qualified professional.

# INSULATING SOLID FLOORS

## *Heritage Assets*

### **Is listed building consent required?**

Listed Building Consent **is required** for insulation of solid floors.

#### **Guidelines for Heritage Assets:**

- Where there are significant, undisturbed, historic floor surfaces, the character and interest could be harmed from being lifted and therefore installing insulation is unlikely to be acceptable. However, where there this is not the case —such as where there is a modern, replacement surface material or there is convincing evidence that a historic floor has been previously lifted and re-laid —the installation of under floor heating may be possible. In which case limecrete should be used which can be used in conjunction with insulation and under floor heating systems whilst allowing the transfer of moisture.

- Breathable materials should be used to maintain the passage of moisture and air.
- Work should be undertaken by a suitably experienced and qualified professional.

#### **Further Guidance:**

[Historic England's Insulating Solid Ground Floors.](#)

## ROOF INSULATION AT CEILING LEVEL

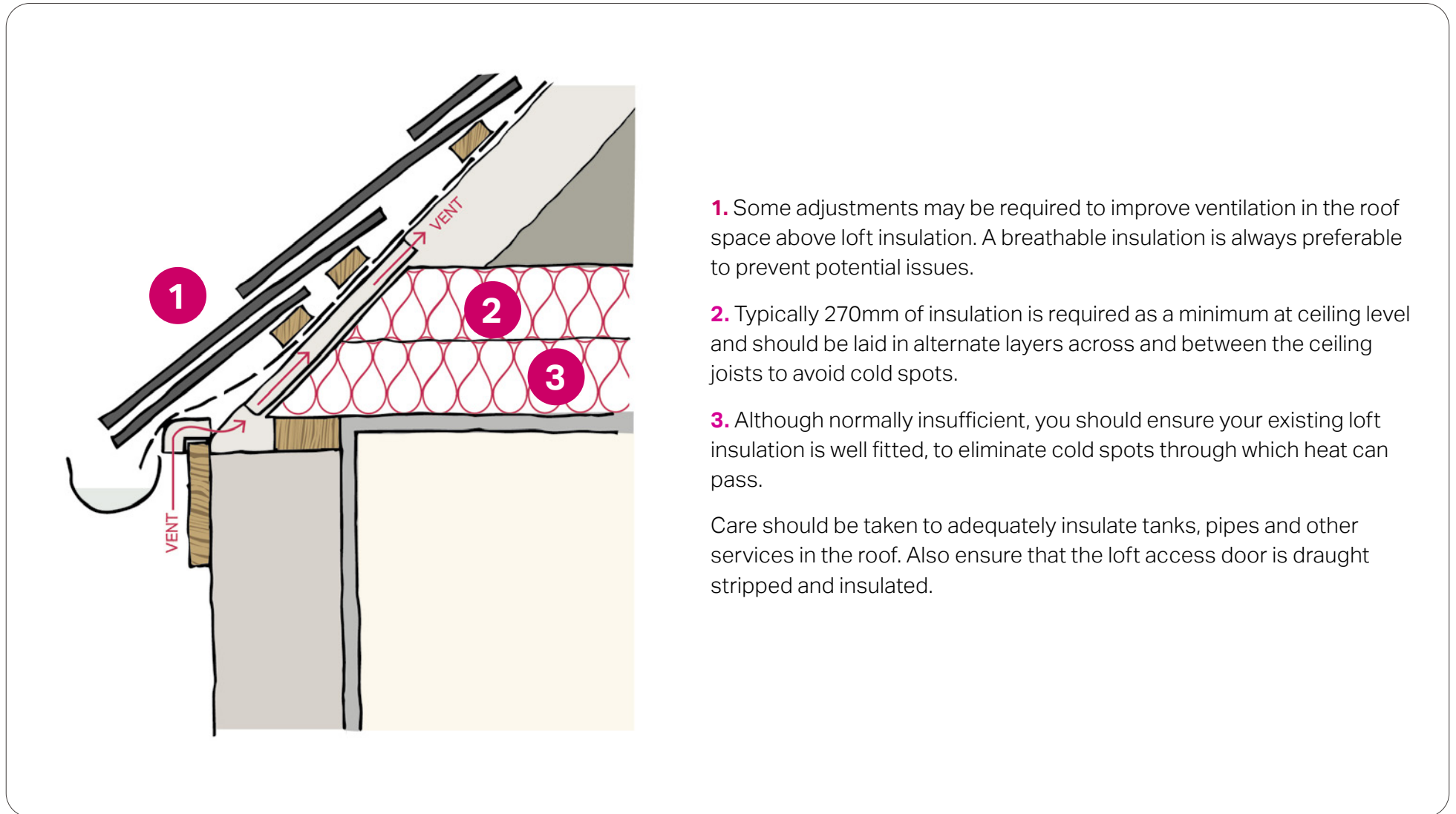

**1.** Some adjustments may be required to improve ventilation in the roof space above loft insulation. A breathable insulation is always preferable to prevent potential issues.

**2.** Typically 270mm of insulation is required as a minimum at ceiling level and should be laid in alternate layers across and between the ceiling joists to avoid cold spots.

**3.** Although normally insufficient, you should ensure your existing loft insulation is well fitted, to eliminate cold spots through which heat can pass.

Care should be taken to adequately insulate tanks, pipes and other services in the roof. Also ensure that the loft access door is draught stripped and insulated.

## ROOF INSULATION AT CEILING LEVEL

### What is it?

The roof of a building is normally simply made from thin tile, slate, or lead coverings on a slender timber frame. With only this and a thin layer of plaster between the upper floor rooms and the outside it is easy to see how heat can be readily lost through an unimproved roof.

Many properties will already have some loft insulation, commonly laid as a loose quilt between the ceiling joists. This arrangement is a good start, but the joists remain uninsulated, the insulation is often too thin and, in many cases, poorly fitted – particularly around the eaves, where the interior is closest to the outside. Top-up insulation is therefore often required.

To achieve adequate performance, it is recommended that loft insulation is the equivalent of c.300mm mineral wool or fibre quilt. The insulation should be laid in layers between and across the timbers so as to reduce heat loss through joints.

Ventilation of the roof space is an important factor to consider as moisture within the roof void should be

encouraged to dissipate through ventilation. It may therefore be necessary to introduce ventilators to improve the air circulation in the roof.

Modern insulation materials are commonly wrapped, to enclose the fibres and ensure the insulation is unaffected by moisture. Care should be taken however as existing and older insulations may have small fibres which can be hazardous in a confined environment.

In addition to improving the insulation levels, loft access doors, tank and pipes should also be insulated. Although normally insufficient, you should ensure your existing loft insulation is well fitted, to eliminate cold spots through which heat can pass.

### How effective is it?

Up to 35% of the heat loss from a home passes through the roof this area is therefore very important to improve.

## ROOF INSULATION AT CEILING LEVEL

### What does it cost?

There are very many insulation systems and products available with strong competition in price to ensure good value. Loft insulation will normally recover its installation cost within 10-18 months. The work can be DIY to reduce cost, but check online to see if there are any current ongoing installation schemes available which subsidise the cost for an installer to fit the insulation.

Remember – improving the fit of insulation you already have will cost you nothing.

For specific **Heritage Asset** guidance on roof insulation measures please refer to the [Insulating Historic Buildings at Loft and Roof Level](#) page of this SPD.

#### Further Guidance:

[Centre for Sustainable Energy: Advice on Loft Insulation](#)



## ROOF INSULATION AT RAFTER LEVEL

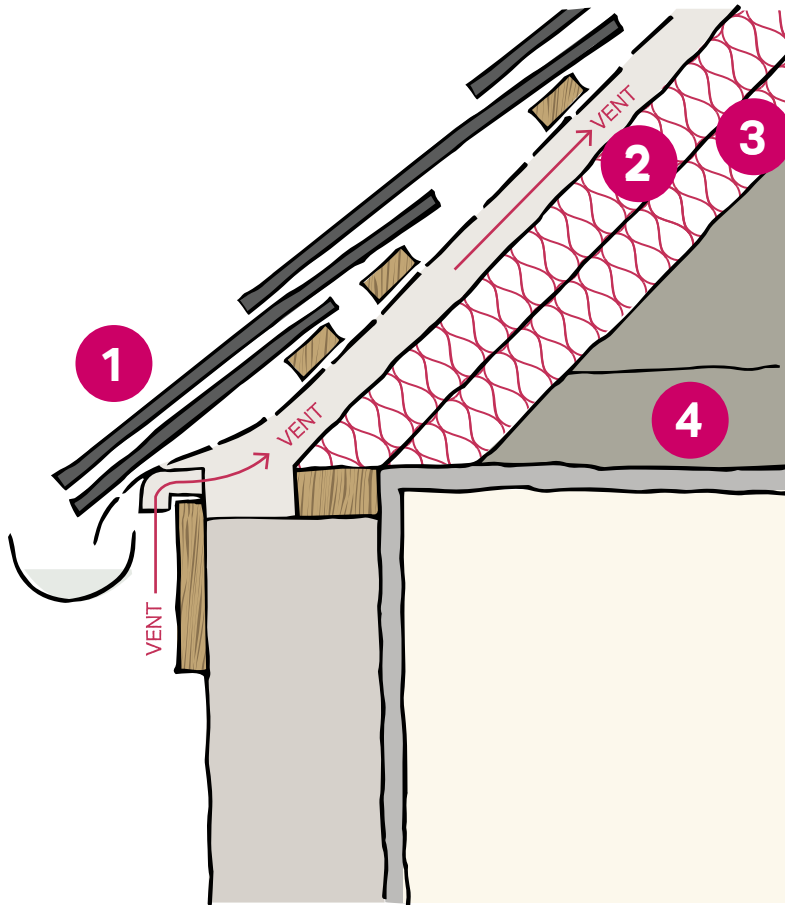

**1.** Some adjustments may be required to improve ventilation of the roof above the insulation. Vents, counter-battens, breathable underlays and the like are basic measures which a builder or roofing contractor could fit.

**2.** Insulation is laid in alternate directions so as to eliminate heat loss through joints.

**3.** Typically, rigid insulation boards are laid between and beneath the rafters to achieve the required level of insulation. Compressible insulation types can be held in place with a net or breathable building membrane.

With insulation at rafter level, the roof can remain useable and tanks, pipes and the like may not need separate insulation.

**4.** Retaining existing insulation at ceiling level will reduce the heat from the home spent warming the roof space.

This measure may require you to remove existing finishes. Also consider ecology—choosing bat-friendly insulation materials where possible.

## ROOF INSULATION AT RAFT LEVEL

### What is it?

The roof of a building is normally simply made from thin tile, slate or lead coverings on a slender timber frame. With only this and a thin layer of plaster between the upper floor rooms and the outside it is easy to see how heat can be readily lost through an unimproved roof.

For some later buildings, there is already insulation at rafter level at rafter level, but most properties will likely have any insulation laid as a loose quilt between the ceiling joists. This arrangement is a good start, but the joists remain uninsulated, the insulation is often too thin and, in many cases, poorly fitted – particularly around the eaves, where the interior is closest to the outside. Top-up insulation is therefore often required.

Insulation at rafter level can be supplemented or newly retrofitted and is typically set both between and beneath the rafters; in alternate directions so as to reduce heat loss through the joints. Rigid insulation boards which are self-supporting can be used, alternatively, soft insulation can be supported with a net or breathable building membrane.

Raft level insulation products are normally higher performing, to reduce the thickness required, but to achieve adequate performance it is recommended that loft insulation is the equivalent of c.300mm mineral wool or fibre quilt.

A ventilation path must be established above the insulation, to dissipate any moisture which could condense on the colder timbers or reduce the performance of the insulation. This will normally only involve basic adjustments of the building by a roofing contractor or builder.

Whilst it could be a little more complex to fit than insulation at ceiling level, rafter level insulation allows the roof space to be used and reduces the need to upgrade loft access, water tanks, pipes, etc. as the roof space is 'warm'.

This technique will likely be required where the ceilings follow the line of the roof and there is no roof space available.

Planning permission or Permitted Development rights would need to be used where the insulation is changing the roof height.

## ROOF INSULATION AT RAFT LEVEL

### How effective is it?

Up to 35% of the heat loss from a home passes through the roof this area is therefore very important to improve.

### What does it cost?

There are very many insulation systems and products available with strong competition in price to ensure good value. Raft level insulation will normally recover its installation cost within 2-3 years. Many systems can be retrofitted from below in less than a day, although some work may need to be undertaken by a contractor, to ensure ventilation routes are achieved.

For specific **Heritage Asset** guidance on roof insulation measures please refer to the [Insulating Historic Buildings at Loft and Roof Level](#) page of this SPD.

#### Further Guidance:

[Centre for Sustainable Energy: Advice on Loft Insulation](#)

# INSULATING HISTORIC BUILDINGS AT LOFT AND ROOF LEVEL

## Is listed building consent required?

- Listed Building Consent **is not normally required** for insulation of pitched roof spaces at floor level, as long as the insulation is not adhesive, avoids disturbance to historic fabric, and is easily reversible.
- Listed Building Consent **is not normally required** for insulation of pitched roof spaces below the roof, as long as the insulation is not adhesive, avoids disturbance or harm to historic fabric and roof profiles, does not cover significant detailing and is easily reversible.
- Listed Building Consent **is not normally required** for installation of pitched roof ventilation and should be discreet.
- Listed Building Consent **is required** for insulation of flat roofs.

For background information on what these measures are, their effectiveness, and cost, including guidelines for non-traditional buildings, refer to the following pages within this SPD:

- **Roof Insulation at Ceiling Level**
- **Roof Insulation at Raft Level**



Each eaves detail needs careful thought once insulation is added. Often bespoke solutions have to be devised to achieve effective improvement

# INSULATING HISTORIC BUILDINGS AT LOFT AND ROOF LEVEL

## Guidance position

The LPA supports careful insulation of loft and roof spaces where there is no detrimental impact on the architecture or historic interest of the building and advocates the use of permeable and sustainable traditional materials.

### Guidelines for Heritage Assets:

- Permeable and traditional materials are preferable.
- Insulation of pitched roof spaces at floor level is always preferable; other options should only be considered where this is not practical or possible (e.g. if the roof space is floored and forms part of the living space)
- Ventilation in the roof space must be maintained. This may require the addition of roof vents – in such cases discreet conservation-grade roof vents should be selected (i.e. eaves vents or tile vents)
- Quilt or rigid board insulation is preferable – sprayed foams will not usually be acceptable as

they are not easily reversible should future repairs be required and are not permeable.

- Be aware of disrupting decorative ceilings.
- Below-roof insulation (pitched or flat roofs) can require temporary removal of surfaces – care should always be taken, and some insulation methods require less removal of fabric than others so research is required into the different options
- Care needs to be taken to preserve in situ historically significant internal surfaces such as plastered or decorated ceilings and skillings
- Roofs can be the least altered areas of historic buildings and care should be taken to maintain historic roof profiles, verge details, plaster surfaces and any other significant features or detailing
- Use of permeable materials, particularly sustainable natural materials such as sheep's wool and wood fibre insulation, is encouraged to minimise the risk of condensation. There are many reputable suppliers of these materials which are produced and sold in the UK.

# INSULATING HISTORIC BUILDINGS AT LOFT AND ROOF LEVEL

## Further Guidance:

[Historic England: Guidance on Insulating Roofs in Historic Buildings](#)

# SOLAR PHOTOVOLTAICS AND SOLAR THERMAL

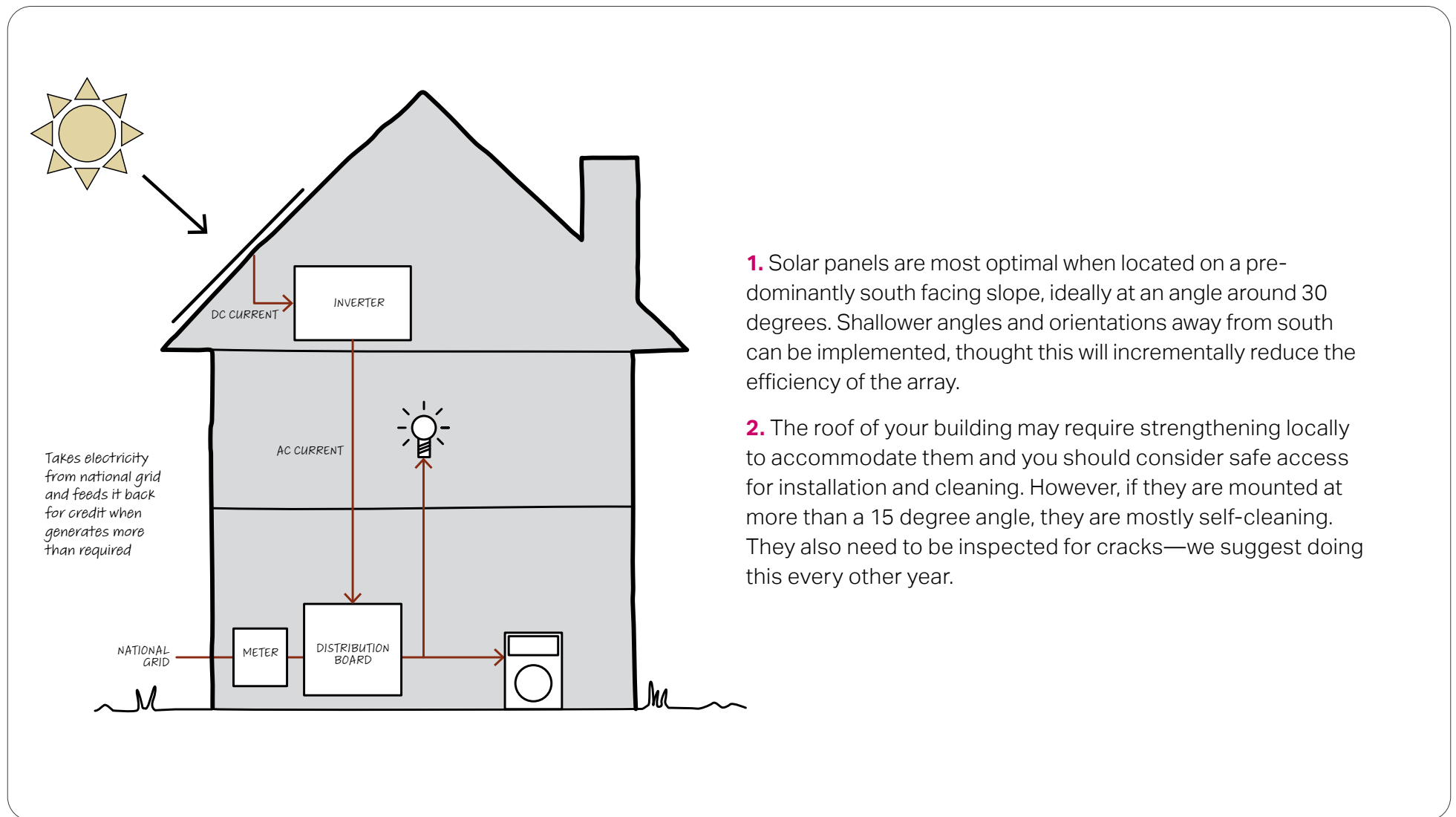

1. Solar panels are most optimal when located on a predominantly south facing slope, ideally at an angle around 30 degrees. Shallower angles and orientations away from south can be implemented, though this will incrementally reduce the efficiency of the array.
2. The roof of your building may require strengthening locally to accommodate them and you should consider safe access for installation and cleaning. However, if they are mounted at more than a 15 degree angle, they are mostly self-cleaning. They also need to be inspected for cracks—we suggest doing this every other year.

## SOLAR PHOTOVOLTAICS AND SOLAR THERMAL

### What are they?

**Solar photovoltaic** (PV) systems use energy from solar radiation to generate electricity. This can be supplied directly to the home or via a connector to the national grid. **Solar thermal**, on the other hand, uses sunlight to heat a fluid (depending on the particular application, it can be water or a water/glycerol mixture).

Solar PV has a big advantage over solar thermal in that it generates electricity, whereas solar thermal is dedicated to heating water or air.

Solar panel installations (both PV and thermal) can be sited anywhere – including free-standing in the garden or on the roof of a property, garage or outbuilding – as long as it does not regularly get overshadowed.

### What does it cost?

The upfront costs of both thermal and solar PV vary significantly depending on the type of system chosen and the area of roof covered. While the upfront costs

of both are usually high, the energy and electricity bill savings can be significant, meaning that you will usually reach a break-even point, in terms of cost, between 12-20 years.

The payback time on the investment for solar thermal tends to be quicker than for solar PV.

### **Heritage Assets**

#### **Is listed building consent required?**

Listed Building Consent **is required** for PV roof slates and solar panels on listed buildings and any buildings within their curtilage.

#### **Guidelines for Heritage Assets:**

- Solar tiles are more widely acceptable if they are a similar colour and appearance to the original tiles.
- Solar slates can also be installed. These look like natural, traditional roof tiles and are more widely acceptable.



## SOLAR PHOTOVOLTAICS AND SOLAR THERMAL

- Solar panels are more widely acceptable if located in a discreet location from the street (but ensure they are not overshadowed for effectiveness).
- If the panels cannot be located on the main building/house roof, consider whether they could be considered appropriate on a outbuilding or garage roof instead.
- Consideration should be given to the weight of solar panels and an assessment of the roof structure should be undertaken by a structural engineer
- Panels must be weighted or tied down to avoid wind lift, which could make the panels too heavy or require a structural intervention in the roof.
- PV tiles have a different appearance to panels, and their visual impact can depend on how much of the roof is covered.
- Where space permits, consider locating panels off the building within the grounds of the building e.g. mounted in the garden.

- If considering recessed panels, consideration should be given to the loss of historic fabric
- Evacuated tube solar thermal systems are more visible than flat-plate panels. However, they require less space, and can be well suited to flat roofs.
- Fixings should cause no damage to significant historic fabric.
- Where a flat roof has a lead covering, a specialist lead contractor should be consulted.
- Thatched roofs are not suitable for solar panels.
- Ensure there is a supply of replacement matching stone/ handmade tiles before the work proceeds, in case of damage.

### Further Guidance:

[Historic England Energy Efficiency and Historic Buildings: Solar Electric \(Photovoltaics\)](#)

[A comprehensive guide to solar panels - Energy Saving Trust](#)

# GROUND SOURCE HEAT PUMPS

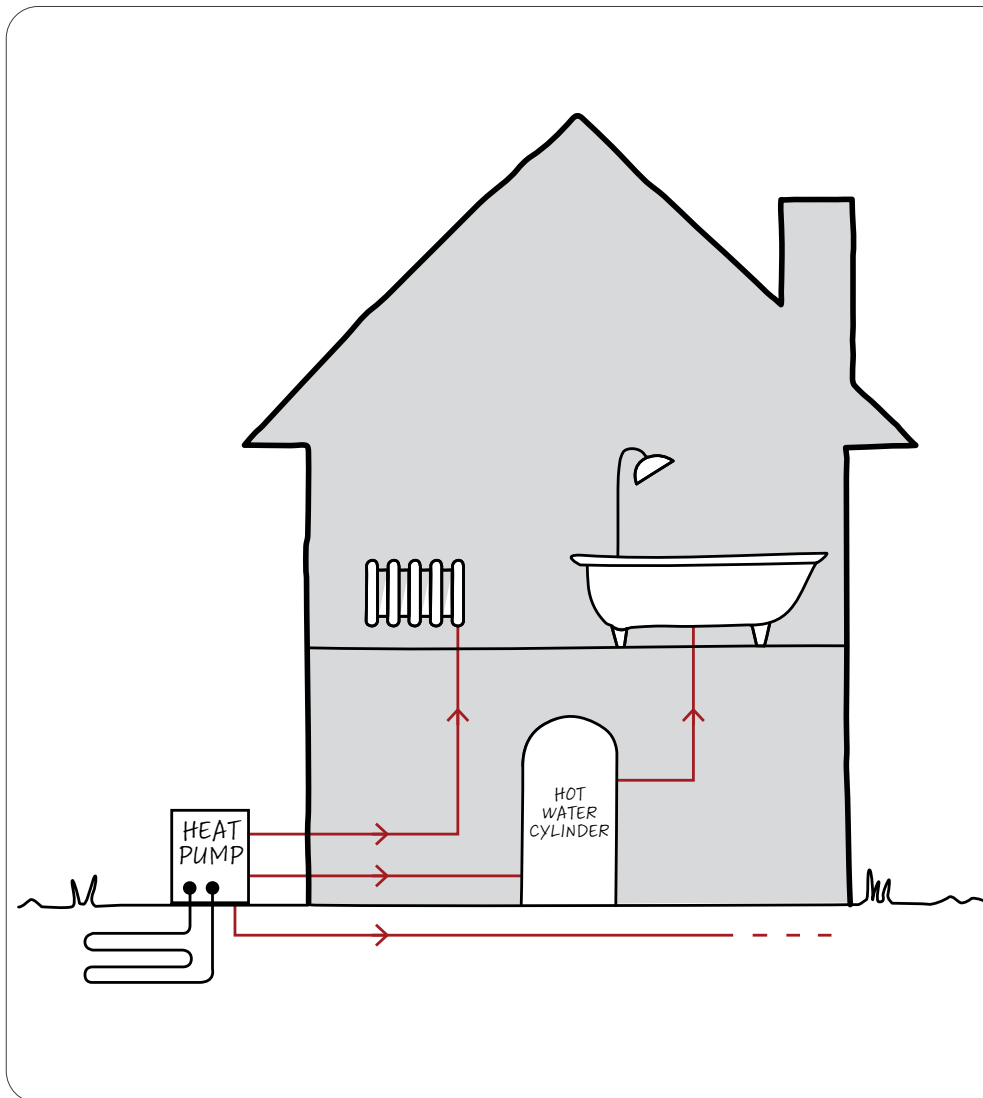

A ground source heat pump slinky awaiting burial.  
Photo copyright: The Centre for Sustainable Energy.

# GROUND SOURCE HEAT PUMPS

## What is it?

Ground Source Heat Pumps use the solar heat energy stored in the ground to provide heat and hot water for a home. 'Ground source' can mean boreholes, slinkies or a 'water source' (open-loop connection to aquifer, lake, or river). Borehole systems require deep vertical holes to be dug, whereas alternative systems are shallower, but cover a wider horizontal area.

They are an alternative to conventional boilers, but operate at lower temperatures, so note that they can be unfeasible without insulation improvements or changes to heat emitters. They are not a direct alternative to combination boilers, as hot water storage must be introduced.

As they operate at lower temperatures, they are well-suited to large heat emitters such as underfloor heating or conventional wet radiator systems.. The system runs at a lower temperature than gas or oil powered systems and it is important that a full heat calculation for the home is undertaken to ensure correct specification of the heat pump and sizing of radiators and hot water tank.

## How effective is it?

Ground sourced heat pumps do not burn fossil fuels and are classed as renewable technology. However, the system does require electricity to operate. Carbon efficiency depend on how green your electrical supplier is.

## What does it cost?

For an average home, the upfront cost of a GSHP installation will be more than a conventional boiler. You should also be aware of potential additional costs of changes to heat emitters or the addition of hot water storage.

Compared to Air Source Heat Pumps, Ground Source Heat Pumps potentially have lower maintenance and replacement costs, although the upfront cost tends to be higher.

## Guidelines to improve efficiency:

Buildings should be well-insulated and the GSHP should be combined with other energy efficiency measures.

# GROUND SOURCE HEAT PUMPS

## Potential issues to be aware of:

- Boreholes can have a detrimental impact on archaeology. Slinkies, an alternative to boreholes, can be even more intrusive in some cases. An archaeological assessment should be undertaken by a professional prior to work commencing.
- Ecology issues such as tree roots and any effect on the temperature of the soil should be checked by a professional prior to work commencing. The ground array designer should size the array to avoid temperatures that would be detrimental to roots.
- Consideration should be given to the location of the internal plant which take up a large amount of space and could require you to break through building fabric. They do not require a flue or gas supply, but do require a flow and return pip connection from the ground outside into the house.

## Heritage Assets

### Is listed building consent required?

Listed Building Consent **is required** where it involves alterations to the listed building.

#### Guidelines for Heritage Assets:

- Boreholes need to have regard to the County of Avon Act (1982) which protects the source of the Bath hot springs (contact the Council for more detailed advice)
- Older properties often contain microbore pipework, which may need to be replaced as it is not usually compatible with a heat pump. Care should be taken when planning pipe runs.

## GROUND SOURCE HEAT PUMPS

- When used for space heating, heat pumps work most efficiently with under-floor heating. This is unlikely to be appropriate under undisturbed, historic floor surfaces. However, where this is not the case, such as where there is a poor quality modern, replacement flooring, the installation of under floor heating may be possible. In which case it is recommended that limecrete is used which can be used in conjunction with insulation and under floor heating systems whilst allowing the transfer of moisture.
- Care should be taken when drilling boreholes adjacent to any particularly fragile structure to avoid damage

### Further Guidance:

[A guide to ground source heat pumps - Energy Saving Trust](#)

[Ground source heat pumps | Centre for Sustainable Energy \(cse.org.uk\)](#)

[Historic England: Guidance on Heat Pumps](#)

# AIR SOURCE HEAT PUMPS

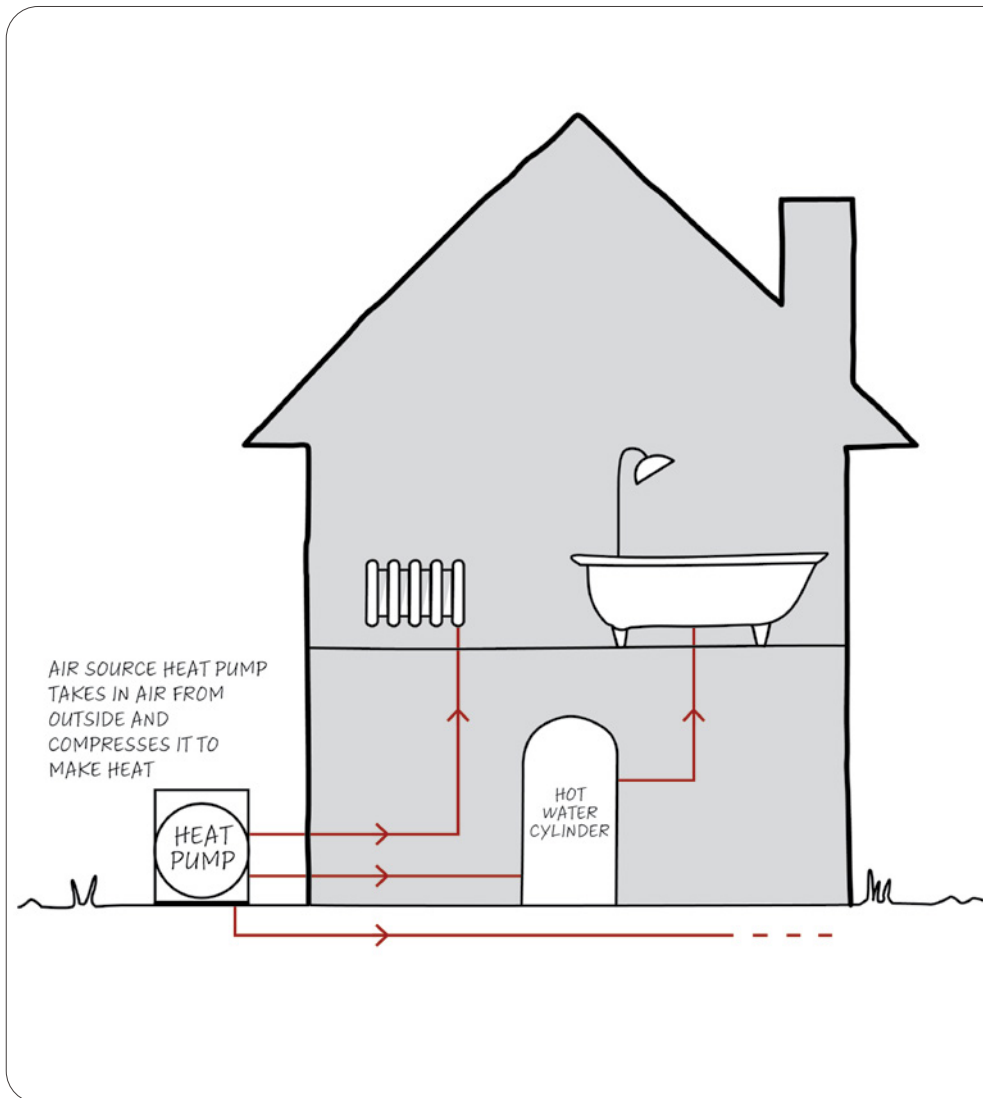

Large-scale air source heat pump installation at roof level.



## AIR SOURCE HEAT PUMPS

### What is it?

Air Source Heat Pumps can be used for heating and cooling spaces in a building. Using the same compression cycle mechanism as a fridge in reverse, they take heat energy from the outside air and transfer it to a refrigerant. The refrigerant is then compressed which significantly increases its temperature and the heat is utilised to heat your home and your hot water. An ASHP is so efficient that it supplies roughly 3 times as much heat energy to the system as it consumes in electrical energy, making them over 300% efficient.

### How effective is it?

- Air Source Heat Pumps are now the low-carbon heating option being promoted in B&NES and elsewhere. They are extremely effective. For perspective, while a modern gas boiler is more than 90% efficient – and electric heaters are 100% – air-source heat pump efficiency can be three or four times higher.
- Air Source Heat pumps are recommended, where possible, to replace oil, log and gas boilers as well as direct electric heating systems (subject to feasibility).
- Carbon efficiency will depend, in part, on how green your electrical supplier is. However, in any case, it is still one of the lowest carbon heating solutions available.
- Heat pumps work most efficiently with underfloor heating. Where this is not possible, conventional radiators can be used effectively for space heating using water heated with an air source heat pump. Radiators should be correctly sized to the needs of the home using a full heat calculation for the property to design the system.
- They can work well when combined with PV Panels and/or battery storage.

## AIR SOURCE HEAT PUMPS

### What does it cost?

Their high efficiency means that an ASHP's running cost can be far lower than what you'd typically pay for an oil-fired or electric heating system and is comparable to gas. An ASHP typically costs less than a Ground Source Heat Pump to install, but note that they have potentially higher maintenance and replacement costs.

Heat pump heating systems work best for homes with a good level of insulation and controllable ventilation. In poorly insulated homes, the running costs may be higher but the carbon emissions will be much lower, especially if the home uses a renewable energy electrical tariff or generates its own with PV panels.

### Potential issues to be aware of:

- The location of the very cold air exhaust from ASHPs should be carefully considered to avoid 'cold plumes' to occupied external areas, or areas where ice may proliferate.
  - Heat pump systems cannot be used for instantaneous hot water like a combi boiler and space will be required for a correctly sized hot water tank.
  - When installed inside the building, ductwork may need to pass through the wall of the building and they will take up space internally.
  - If you intend to also use the heat pump for cooling, this should be built into the initial design.
- Noise emissions should be considered and mitigated where needed with a silencing enclosure, or by locating the unit further from sensitive facades.



# AIR SOURCE HEAT PUMPS

## Heritage Assets

### Is listed building consent required?

Listed Building Consent **is required** for an air source heat pump.

#### Guidelines for Heritage Assets:

- Buildings of a traditional construction require a level of passive natural ventilation and the design of the heat pump system will need to allow for the lower levels of insulation and higher rate of ventilation.
- Care should be taken to locate the external unit of an air source heat pump in a discreet location away from the principal elevation – this could include behind greenery or fencing. You can also find ducted ASHP units which can be located indoors.
- If under-floor heating is not possible, radiators may be considered. In some cases, historic radiators may survive and are likely to be considered as significant elements of the interior and therefore their

retention is important. Where this is not the case, new radiators should be of a discreet design and sensitively-located.

- Older properties often contain microbore pipework, which may need to be carefully replaced as it is not usually compatible with a heat pump.
- When used for space heating, heat pumps work most efficiently with under-floor heating. This is unlikely to be appropriate where there are significant historic floor surfaces which could be harmed from being lifted. However, where there is not the case, such as where there is already modern, replacement flooring, under floor heating may be possible. In which case, it is highly recommended that limecrete is used which can be used in conjunction with insulation and under floor heating systems whilst allowing the transfer of moisture.

#### Further Guidance:

[Historic England: Guidance on Heat Pumps](#)

[Centre for Sustainable Energy: Air Source Heat Pumps](#)

# MECHANICAL VENTILATION AND HEAT RECOVERY

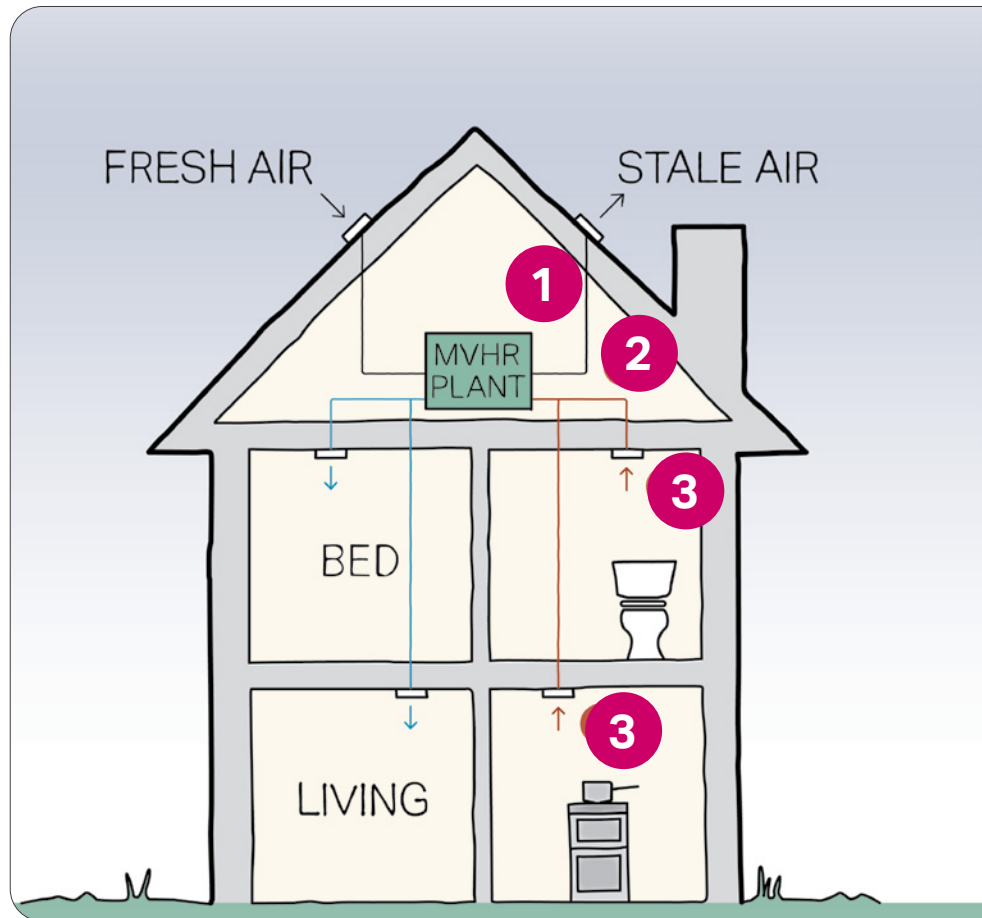

**1.** All extract is taken through 2 outlets: intake and exhaust. They should be at least 1 metre apart, ideally 2 metres or more. They can be discreetly located on the building, for example at roof level, but ideally as close as possible to the fan unit to avoid heat loss from the cold outside air to the ducts.

**2.** Ductwork will be required to connect the various extract outlet and supply inlet locations to the MVHR plant. Some slimline systems are available which can fit inside partition and ceiling voids.

**3.** The MVHR plant can be installed in a concealed location such as a cupboard or roof space.

Extracts from kitchens, living rooms, WC's and utility rooms at lower floors and bedrooms, bathrooms, shower rooms and ensuites at upper floors can all be connected to the MVHR system.

# MECHANICAL VENTILATION AND HEAT RECOVERY

## What is it?

Mechanical ventilation and heat recovery systems (MVHR) combine the various extract fan functions in a home with a small heat exchanger. This takes warmth from the waste air being removed and uses it to heat the incoming air which is replacing it.

MVHR is very effective at tackling condensation and air quality which is a major risk factor when improving energy efficiency, especially in historic buildings.

## What does it cost?

The cost-benefit ratio of the MVHR system depends on the home being airtight. In addition to the cost of the system, you would also have to consider the cost of professional installation, and the cost of filter replacements.

## How effective is it?

For MVHR systems to be effective, the home must be airtight. In draughty homes they are less beneficial because the uncontrolled air provides enough vent. In well sealed homes the MVHR provides a reduction in heating energy at the expense of some fan energy, and helps to make sure there is enough ventilation.

Passive systems are also available which use wind pressure and thermal stack-effect to naturally move air through the system and these can be useful in some situations where the benefit is otherwise marginal.

As with all ventilation improvements, there are potential benefits to health for households with damp problems.

# MECHANICAL VENTILATION AND HEAT RECOVERY

## Heritage Assets

### Is listed building consent required?

Listed Building Consent **is required** to install and for an extractor fan or heat-recovery ventilation system.

#### Guidelines for Heritage Assets

Excessive moisture levels can lead to condensation and mould and bacterial growth, which can be harmful to historic building fabric and human health, so controlled ventilation is recommended. MVHR is a very effective way of reducing moisture levels to avoid condensation.

- Principal elevations should be avoided. Where it can be successfully justified that there is no alternative, discreet outlet styles and colours will be of paramount importance.
- Specify an outlet of a discreet style and colour that matches the surrounding wall colour as closely as possible.

- If possible, offer to remove redundant services from the wall where they are no longer required as a Conservation gain
- Consider locating the exhaust through a vertical flue in a roof that cannot be seen.

#### Further Guidance:

[The Domestic Building Service Compliance Guide \(2010\)](#)

[Natural Ventilation for Traditional Buildings](#)

## BOILERS AND HEATING CONTROLS

### What is it?

Rainwater harvesting is the collection of rainwater from roofs or hard-standings for use for toilet flushing, laundry water supply or irrigation.

Rainwater Harvesting systems collect rainwater from your roof or other surfaces and store it for later use - the water is not to be used for drinking, cooking or showering. Water can be stored in over-ground tanks (often located in sheds, outhouses or garages). If short on space the tanks can be stored underground. Filters and pumps are then used to provide water to the building or a tap nearby. Additional filters can be used to make the water suitable to drink, however, these can be a more expensive add on.

Greywater recycling is the use of waste water from baths, showers and hand basins for toilet flushing, irrigation or washing machine supply. The definition of greywater excludes sewage and also waste water from kitchen sinks.



Adjustable heating control. Photo copyright: The Centre for Sustainable Energy

### It's important to note...

There is a large contrast in CO<sub>2</sub> emissions between the high levels emitted by gas boilers and the very low levels from renewable sources, which we recommend, such as heat pumps. For this reason, it is the Government's intention to phase out new gas boilers by 2025.

## BOILERS AND HEATING CONTROLS

### How effective is it?

It is most effective to reduce your water use. After you have done this, it is worth considering rainwater harvesting.

Rainwater harvesting systems are easiest to fit when you are building a house or doing significant renovation as it will require changes to the plumbing system and potentially digging for water tank if stored underground.

Household rainwater systems reduce demand on drinking water supplies and decrease pressure on storm-water drains and sewers. Rainwater collected can be stored and used for garden use, car washing, WC flushing and washing machine use. Industrial pollution, contamination from bird droppings and other dirt means that rainwater is rarely used for other uses.

### What does it cost?

We recommend using the UK Rainwater Management Association website for up-to-date price estimates of good quality domestic rainwater harvesting systems. The cost of running the pump is estimated to be very low. If you are on a water meter, it is estimated that the payback period for a rainwater harvesting system would be 10 to 15 years.

Use an online rainwater calculator to find out if it is worth looking at rainwater harvesting for your house.

An alternative cheap, or free, DIY option is to use water butts or buckets outside to collect and recycle water.

# BOILERS AND HEATING CONTROLS

## Heritage Assets

### Is listed building consent required?

Listed Building Consent **is required** for rainwater harvesting systems and support will be given to sensitively detailed schemes.

The alternative DIY rainwater harvesting option of simply using water butts or buckets to collect and recycle water. For heritage assets, this is likely to be the most appropriate approach and **does not require** listed building consent.

#### Guidelines for Heritage Assets:

- Plumbing routes should avoid notching floor joists and should be installed parallel to them to avoid harm to historic fabric and possible structural problems.
- Principal elevations should be avoided. Discreet and appropriate outlet styles, dimensions and colours will be of paramount importance. Specify an outlet of a discreet style, size and colour that

match the surrounding wall as closely as possible to minimise its impact.

- Where practical, put the exhaust through a vertical flue in a roof that cannot be seen
- Care should be taken when planning new pipe runs to avoid damaging historic surfaces and decorations (e.g. when lifting and re-laying floorboards).
- Flues will need to be appropriately located to ensure compliance with the Building Regulations.

#### Further Guidance:

[The Environment Agency's Guide to Rainwater Harvesting for Domestic Uses](#)

[UK Rainwater Management Association](#)

# RAINWATER HARVESTING

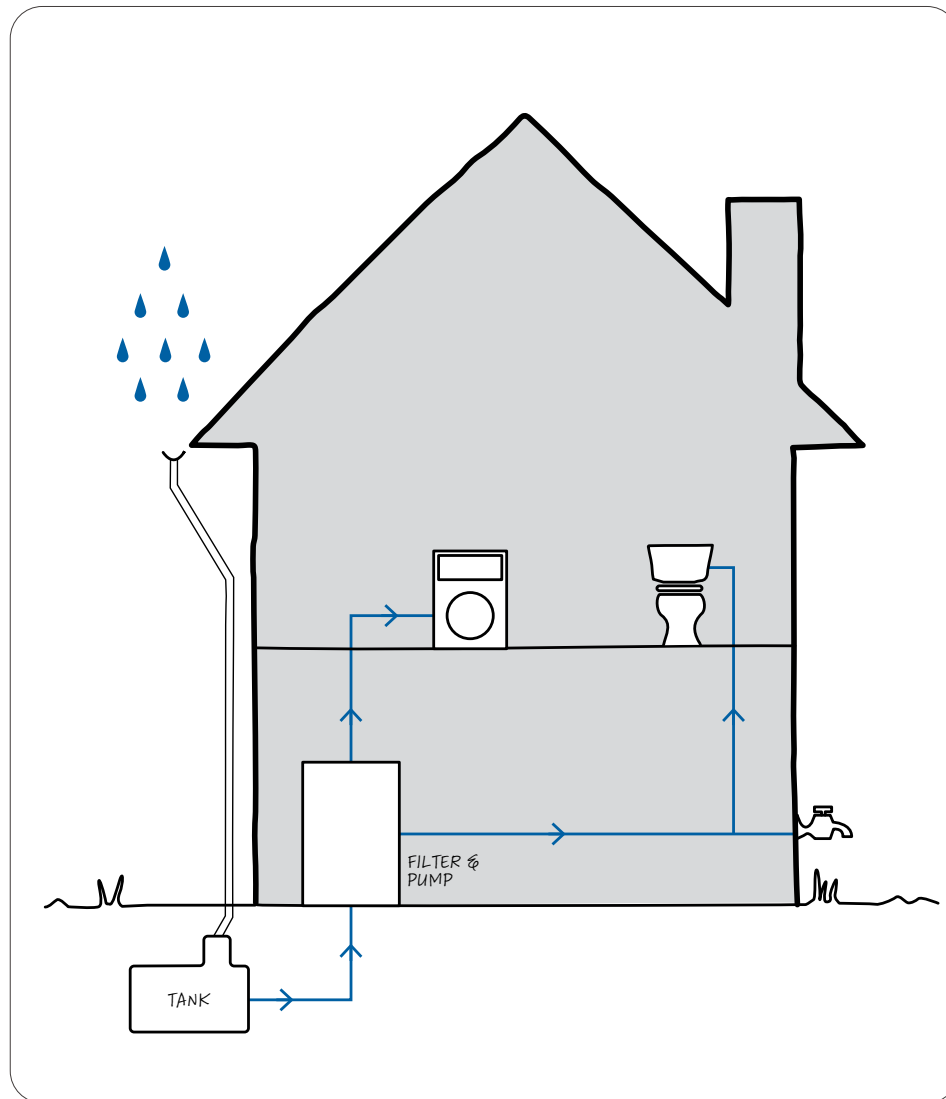

## What is it?

Rainwater harvesting is the collection of rainwater from roofs or hard-standings for use for toilet flushing, laundry water supply or irrigation.

Rainwater Harvesting systems collect rainwater from your roof or other surfaces and store it for later use - the water is not to be used for drinking, cooking or showering. Water can be stored in over-ground tanks (often located in sheds, outhouses or garages). If short on space, the tanks can be stored underground. Filters and pumps are then used to provide water to the building or a tap nearby. Additional filters can be used to make the water suitable to drink, however, these can be a more expensive add on.

Greywater recycling is the use of wastewater from baths, showers and hand basins for toilet flushing, irrigation or washing machine supply. The definition of greywater excludes sewage and wastewater from kitchen sinks.



## RAINWATER HARVESTING

### How effective is it?

It is most effective to reduce your water use. After you have done this, it is worth considering rainwater harvesting.

Rainwater harvesting systems are easiest to fit when you are building a house or doing significant renovation as it will require changes to the plumbing system and potentially digging for water tank if stored underground.

Household rainwater systems reduce demand on drinking water supplies and decrease pressure on storm-water drains and sewers. Rainwater collected can be stored and used for garden use, car washing, WC flushing and washing machine use. Industrial pollution, contamination from bird droppings and other dirt means that rainwater is rarely used for other uses.

### What does it cost?

We recommend using The UK Rainwater Management Association website for up-to-date price estimates of good quality domestic rainwater harvesting systems. The cost of running the pump is estimated to be very low. If you are on a water meter, it is estimated that the payback period for a rainwater harvesting system would be 10 to 15 years.

Use an online rainwater calculator to find out if it is worth looking at rainwater harvesting for your house.

An alternative cheap, or free, DIY option is to use water butts or buckets outside to collect and recycle water.

# RAINWATER HARVESTING

## *Heritage Assets*

### **Is listed building consent required?**

Listed Building Consent **is required** for rainwater harvesting systems and support will be given to sensitively detailed schemes.

The alternative DIY rainwater harvesting option of simply using water butts or buckets to collect and recycle water. For heritage assets, this is likely to be the most appropriate approach and **does not require** listed building consent.

#### **Further Guidance:**

[The Environment Agency's Guide to Rainwater Harvesting for Domestic Uses](#)

[UK Rainwater Management Association](#)

# GREYWATER HARVESTING

## What is it?

Greywater recycling is the use of waste water from baths, showers and hand basins for toilet flushing, irrigation or washing machine supply. The definition of greywater excludes sewage and also waste water from kitchen sinks.

## How effective is it?

First, it is most effective to reduce your water use (see the **Energy Saving 'Quick Wins' Checklist** page of this SPD for tips on how to save water and energy. After you have done this it is worth considering greywater recycling.)

Around 33% of our average water usage comes from showers, basins and baths. This grey water can be recycled and reused for the flushing of toilets, which are calculated to use a further 30% of domestic water usage.

## What does it cost?

You will see immediate reduction in water bills if you have a water meter following the installation of a greywater recycling system in your home. The systems are suitable for inclusion in a new build home as well as being retrofitted into an existing one, although the costs will differ.

## Heritage Assets

### Is listed building consent required?

Listed Building Consent **is required** for grey water harvesting systems in listed buildings.

#### Guidelines for Heritage Assets:

- The LPA supports the careful installation of greywater harvesting systems by a suitably qualified professional.
- Support will be given to sensitively-designed greywater harvesting systems which align with the advice in the **Heritage Guidance Position** stated in the Introduction and Policy Forward of this SPD.

#### Further Guidance:

[The Environment Agency's Guide to Grey Water Harvesting for Domestic Uses](#)

**CHAPTER 3:**  
SUSTAINABLE CONSTRUCTION

## LAND-USE & ECOLOGY

Whenever we build, we must protect and plan for the plants and animals that already live on the site. We should also look for opportunities to enhance and create new habitats and support biodiversity.



**Bath Asparagus at Peasedown St John** Can existing plants be retained?



**Pond at Weston All Saints Primary School, Bath** Are there opportunities to enhance habitats and biodiversity?

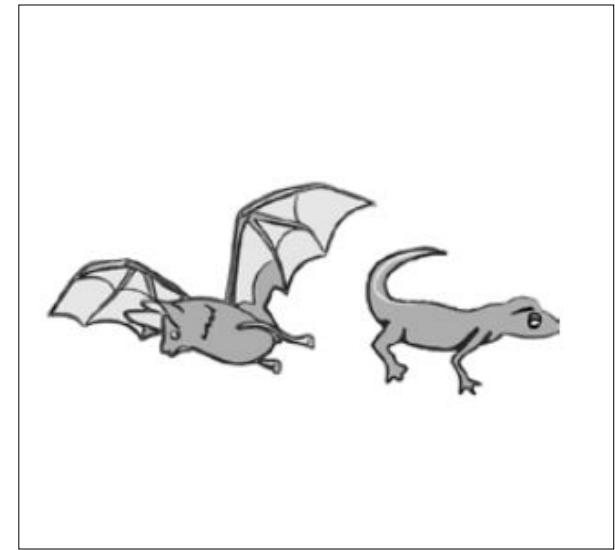

Some animals & plants are legally protected. Are there any at your site? To find out, a protected species survey may be required. For example, bats may roost in trees and buildings, and a pond may contain great crested newts.



## LAND-USE & ECOLOGY



What is your development doing to help protect living creatures such as birds, insects, mammals, and reptiles?



Look out for opportunities for enhancements e.g. can you incorporate bird boxes, swift bricks or bat boxes in your design?



For many sites, it is important to carry out an ecological survey prior to any work starting to identify the flora and fauna that need to be protected.

## LAND-USE & ECOLOGY

Land on sites should be used efficiently with new planting supporting existing local species of flora and fauna. Opportunities to connect and introduce multi-functional green infrastructure should be considered e.g. by adding green roofs, street trees or space for growing food.

**The following are good sources of information on how to identify and protect animals and plants on your construction site:**

The district's [Requirements for Biodiversity and Geological Conservation Assessment](#) can be found on the Council's planning web pages. The Council's Ecologists can advise further if required.



### [Natural England](#)

Guidance on protected species such as bats.



### [Bristol Regional Environmental Records Centre](#)

A primary source of and repository for local wildlife and geological data.



### [Avon Wildlife Trust](#)

A leading local wildlife charity and additional source of information and advice.



### [Wildthings Biodiversity Action Plan](#)

Highlights wildlife of local importance and promotes the use of native species and describes their benefits. This is particularly important for new planting schemes.

### [Green Infrastructure Strategy](#)

Find out more about the Green Infrastructure networks in your area which include open spaces, parks and gardens, allotments, woodlands, street trees, green roofs, fields, hedges, lakes, ponds, playing field, as well as footpaths, cycleways and waterways. Consider how your development can strengthen and connect to local green infrastructure.

## SITING & ORIENTATION

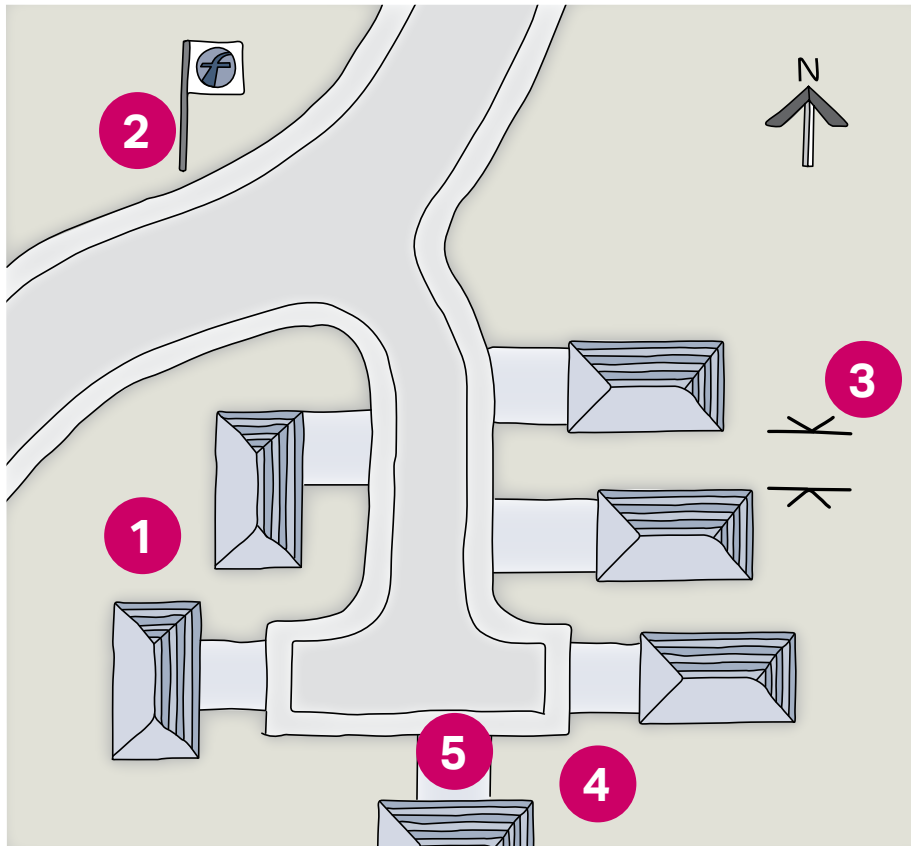

### Comments on Example Scheme

1. Very restricted south facing roof surface.
2. Is the site maximising access to public transport? Is walking and cycling designed into the scheme? What is more accessible cycle parking or car parking? Have pedestrian routes been fully considered?
3. Buildings in close proximity to each other can block out their neighbours natural daylight and overshadow neighbour's roofs, reducing their ability to use solar power.
4. Plenty of south facing roof – even if the intention is not to install solar panels during construction, make the roof 'solar ready' for future installation.
5. A path, driveway or front garden of 5m<sup>2</sup> or more that is impermeable will require planning permission. It is usually much better to finish with porous surfaces that allow rain falling on the site to drain locally rather than overburdening the existing drainage systems. See Surface Water Run-off section.



## SITING & ORIENTATION

When siting new buildings, there is an opportunity to orient them to:

- Maximise natural daylight and sunlight into the building. See **Passive Design**.
  - Ensure that the largest part of the roof's surface is facing South, or at least SSE/SSW so that any solar panels on the roof have maximum access to the sun.
  - Maximise the roof pitch angle to be PV ready in future
  - South facing elevations could utilise naturally ventilated conservatories and sun lobbies to control solar gain within dwellings. See **Passive Design**.
  - Consider the topography of the land and character of the place together with solar orientation when siting and laying out your new building. The [Building for Life Tool](#) on the Design Council website can help with this.
- Space can be left around the main buildings to allow for rainwater collection and the use of Sustainable Urban Drainage Systems or SUDS in the landscaping around dwellings. See **Water and Surface Water Run-off** sections for details.
  - When considering the siting of solar thermal systems the supply and demand of hot water should be considered to maximise their efficiency e.g. early morning hot water for showers.

# SITING & ORIENTATION

## Solar Panels

Solar thermal panels heat the hot water for the building Photovoltaics generate electricity for the building. The feed in tariff scheme will generously compensate you for generating your own electricity. See [www.energysavingtrust.org.uk](http://www.energysavingtrust.org.uk)

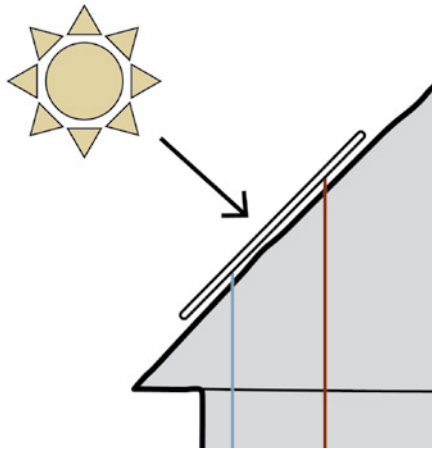

## UK solar radiation

The south west is well placed nationally for solar energy!

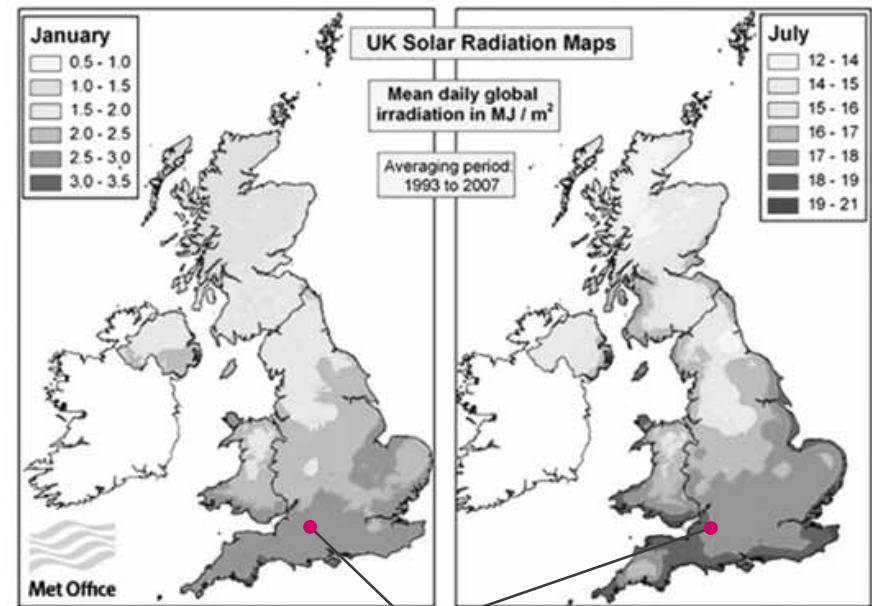

Bath & North East Somerset

# PASSIVE DESIGN

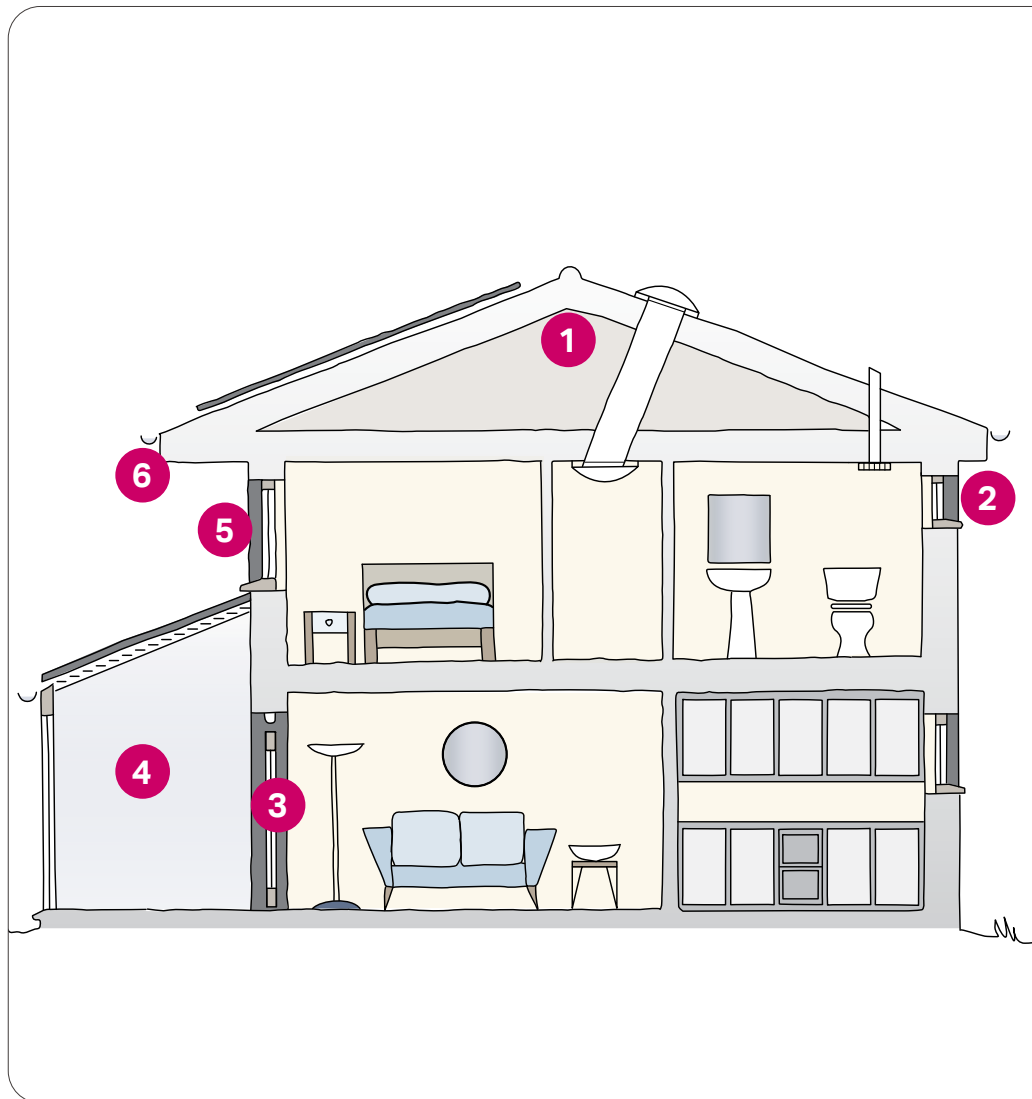

## Example Scheme

### Comments on Example Scheme

1. Insulation in the roof helps keep heat in during the winter and out during the summer
2. Smaller windows on the north side help to reduce heat loss where the sun doesn't shine
3. Make sure the wall between the main building and the conservatory is built as an external wall to ensure minimal heat loss in winter.
4. Conservatories on the South (or SSW/SSE) side of the building can capture huge amounts of free, carbon neutral energy from the sun. If the floors are solid (ceramic tile or stone for example), they can soak up the heat from the sun over the course of the day and release it in the evening (see Thermal Mass)
5. Large south facing glazing or windows will let lots of natural light in, avoiding using artificial light, but make sure you can shade in summer. External blinds, brise soleil and shutters can all help control the amount of daylight and sunlight entering the building
6. Consider solar shading in your design, for example the use of a roof overhang, blinds, shutters or even natural tree shading or green walls/roofs.

## PASSIVE DESIGN

Although 'active' systems such as solar panels and other renewable energy technologies play a part in reducing carbon emissions, a less expensive and longer-term option is to use 'passive' measures such as:

- Well placed windows for maximum daylight and to provide natural ventilation.
- Natural stack ventilation through chimneys can also be designed into new buildings
- Thermal mass to absorb and release the sun's energy. Please read this section together with Thermal Mass section as they are interrelated.
- Conservatories and sunspaces can capture passive solar energy. However, there should be a division between these and the rest of the house to help control heat flow.
- A conservatory or sunspace can otherwise drain heat from the main house in the winter or lead to overheating in the summer.
- Sun pipe light tubes can be used to redistribute natural daylight to interior spaces.

# THERMAL MASS

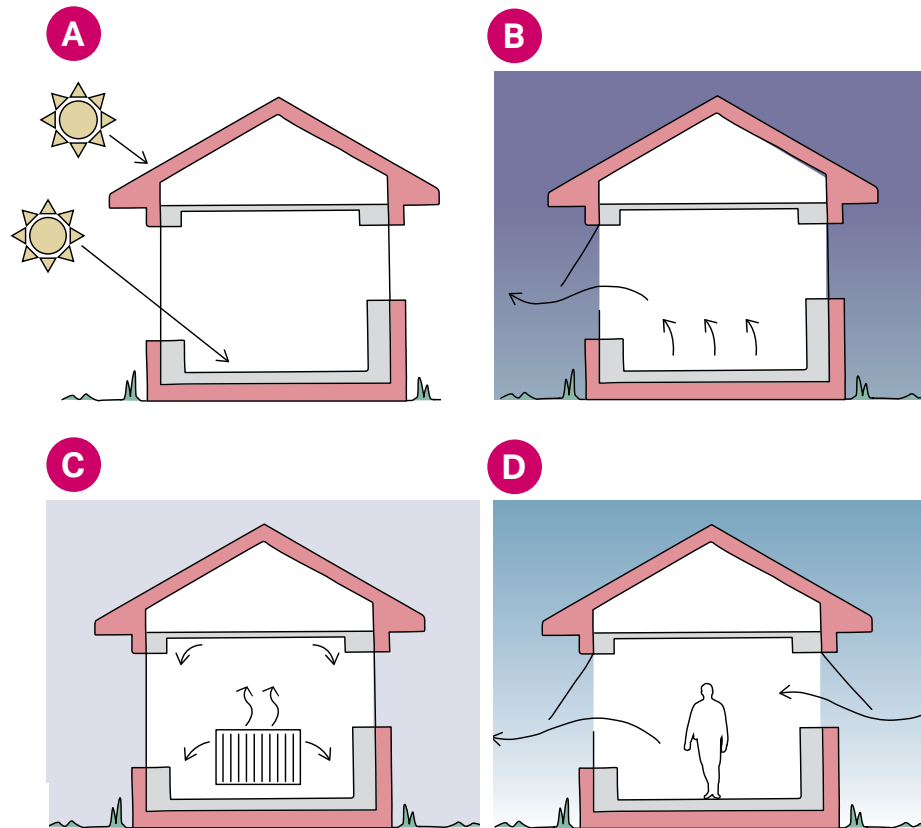

Building materials that are heavyweight (brick, block, concrete) can be used to absorb and release heat in buildings and help moderate the temperature.

**A.** During the day: Its important on south facing facades to try and keep the highest summer sun out by using roof overhangs & solar shading Heavyweight walls, floors and ceilings (thermal mass can absorb the suns heat and help keep the building cool).

**B.** At night time: Opening windows at night lets heat out and allows cooler air from outside to cool the thermally massive elements and reduce overall temperature: 'night time cooling'. In the morning, the building is ready to start the cycle again. In addition to helping cool buildings in summer (an important consideration with scientific predictions of hotter summers) thermal mass can help keep heat in winter if the insulation is on the outside.

**C.** Heat from inside the building warms up the thermally massive materials and then the insulation on the outside keeps the heat in – like a giant tea cosy over the building. Take care to ensure that the insulation is continuous and there are no gaps causing 'cold bridging'

**D.** Another benefit of thermal mass is that it helps to iron out the peaks and troughs in temperature, making indoor temperatures more comfortable for the occupants.

Don't forget to ensure there is adequate ventilation too – in summer, a breeze makes people feel more comfortable even at relatively high temperatures.

# SURFACE WATER RUNOFF

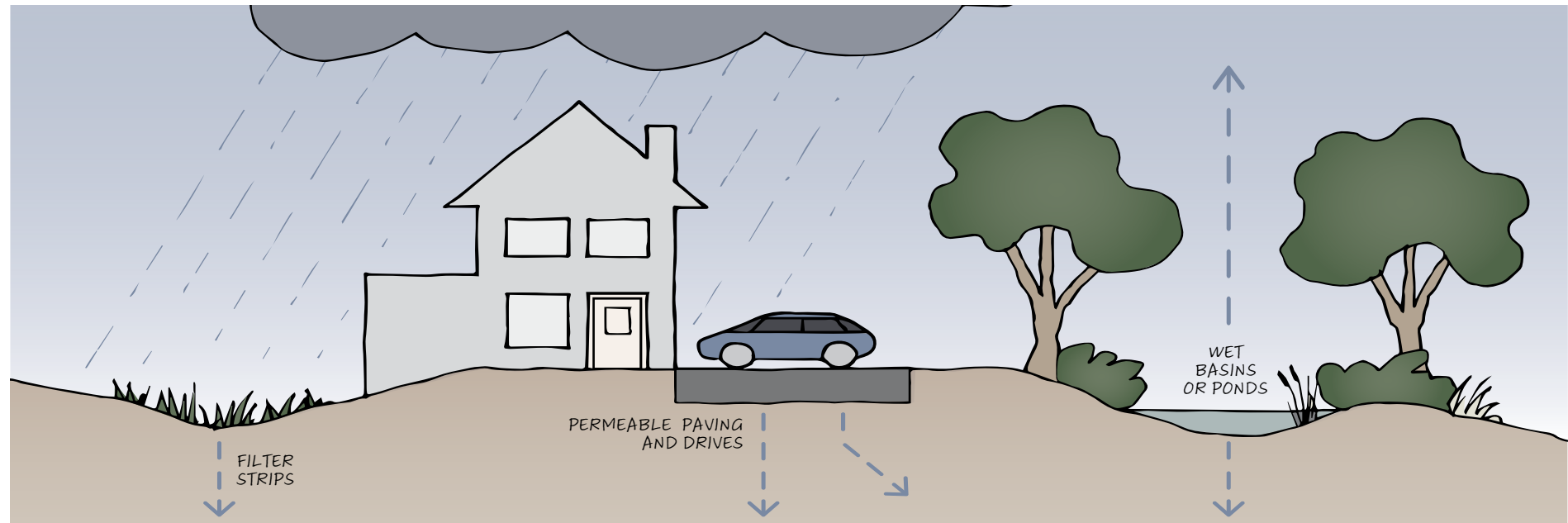

## Embodied Energy and Thermal Mass

The embodied energy of materials and the use of the building is also an important consideration in any build project for example sustainably sourced timber has low thermal mass but less embodied energy. Modern construction materials such as straw bale have both excellent thermal properties and a low environmental impact.

As cities grow, the amount of land we cover with impermeable surfaces such as tarmac, increases. As our climate changes, it is predicted that we will get more extreme weather including severe rainstorms. When it rains heavily, drains cannot cope, and this can lead to problems such as flash flooding. Guttering and drainage systems need to be designed with increased rainfall in mind as part of a climate change adaptation strategy.

Sustainable Urban Drainage systems can be incorporated to reduce the potential impact of new and existing developments in terms of surface water drainage.

Simple, natural solutions can often be possible although for some sites engineering options will need to be explored. Sustainable drainage is a requirement of the Flood and Water Management Act 2010, which is enforced through the planning system.



The River Avon bursting its banks in central Bath after severe rain.



Green roofs can help reduce pollution and surface water run-off and are particularly useful in dense urban areas.

The solution is to introduce permeable surfaces on paths, drives and car parks, so that when it rains, the ground absorbs the water and the sewage system does not become over-burdened.

## Case Study:

The Sustainable Urban Drainage system at Weston All Saints Primary School, Bath. This scheme shows that with intelligent design SUD systems can incorporate natural play space and bring visual interest and opportunities for new habitats.

### Useful links:

A Community for sharing information on sustainable drainage: [www.susdrain.org](http://www.susdrain.org)

Guidance for urban rain gardens:  
[www.raingardens.info](http://www.raingardens.info)

Information on various types of green roofs:  
[www.livingroofs.org](http://www.livingroofs.org)

# WATER

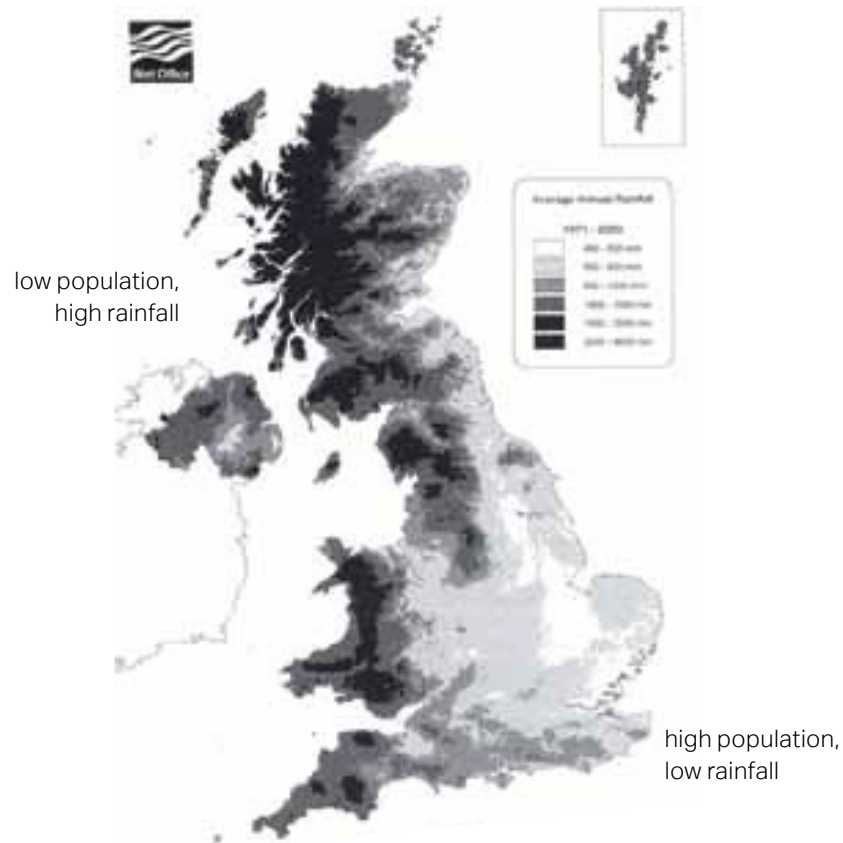

We have a fixed amount of water on the planet so we are not going to run out. However, each time we 'clean' used water we use energy, so we need to manage our water use effectively.' For some uses, such as flushing WC's, we do not need to use drinking water – rain water will do the job very well. In the UK, we have areas of water stress – the parts of the country with the most rain are the least populated.



# WATER

## There are simple ways to use less water:



Low flow shower heads



Flow restrictors on taps



Low flush, dual flush WC's

## And by changing your behaviour:



Turning off the taps when you don't need running water



Showering rather than having a bath

## You can also reduce your reliance on processed mains water:



Greywater Harvesting



Rainwater Harvesting

- Greywater recycling is the use of waste water from baths, showers and hand basins for toilet flushing, irrigation or washing machine supply.
- Rainwater harvesting is the collection of rainwater from roofs or hard standings for use for toilet flushing, laundry water supply or irrigation.

You can find out more about water saving opportunities and can often get free gadgets from water utility companies such as Wessex Water – [www.wessexwater.co.uk](http://www.wessexwater.co.uk) and Bristol Water – [www.bristolwater.co.uk](http://www.bristolwater.co.uk)

**Environment Agency** studies show that CO2 emissions from water use in households come mostly from heating water. CO2 emissions from a hot water storage cylinder and pipes contribute significantly and can only be reduced by energy efficiency measures such as improved pipe or cylinder insulation rather than using less water.

# ENERGY

## There are two ways buildings use energy:



**During construction** embodied energy: this term refers to the total energy required to manufacture or construct an object, material or building.



**During use** operational energy: this is the energy which is used on a daily basis for heating and electrical appliances.

## You can reduce the amount of energy your building is responsible for by:

### 1. Using low impact materials



High levels of insulation

### 2. Making your building more energy efficient

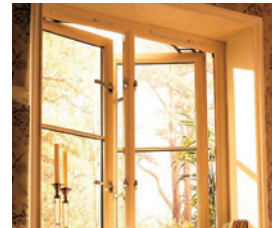

High performance windows



Use of natural light



Use low energy lighting

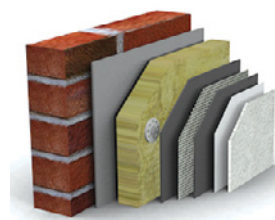

Install heating controls



Monitoring to check your energy usage



Avoid overheating in summer

**You can also use low carbon technologies to reduce the amount of fossil fuels to heat, light and cool your buildings, such as:**



Biomass (if a local supply can be secured)



Solar thermal panels for hot water



Solar photovoltaic panels for electricity generation



Wind turbines (where appropriate)



Air source heat pump



Ground source heat pump



# MATERIALS

Most of the materials we use come from non-renewable sources, and sooner or later we will run out. It also takes energy (usually from fossil fuels) to make building products thereby contributing to climate change. We can help to address this by using sustainable materials...

Seek natural, environmentally friendly, locally sourced materials e.g. sheep's wool insulation

Did you know that Kingston University has catalogued over 1,200 recycled materials for use at the construction industry in its Sustainable Materials Library?

**Rematerialise** is both an online resource and a library you can visit and only contains items that come from renewable resources or less non-renewable resources.

## Responsibly sourced used materials

eg. reusing roof tiles



## Materials with recycled content

eg. old newspapers as insulation



## Materials that can be recycled

It takes 95% less energy to use recycled aluminium than virgin aluminium



## Renewable Materials

FSC (Forest Stewardship Council) timber for wood floors.



# WASTE

Constructing buildings creates huge amount of waste – over 100m tonnes each year – over a third of all waste created in the UK. Consider how existing buildings on a site can be retained and adapted for re-use. We can make a big difference by:

Whether its construction waste, or waste from households, industry etc, we have to reduce the number of materials we use in the first place and reduce waste – otherwise known as an 'unused resource'

**Do you have a site waste management plan? This could save you money!**

**Designing our buildings to use materials more effectively**

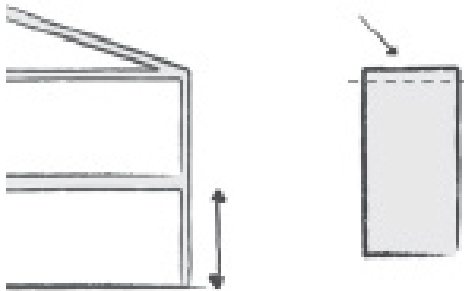

**Using less material**



**Segregating waste onsite for recycling**



**Using 'waste' to produce new building materials**



# LEGISLATION & ASSESSMENT TOOLS

## Building Regulations:



## Assessment Tools:

### [The Association for Environment Conscious Building \(AECB\) Standards](#)



The AECB Building Standards allows for easy self-certification and increasing comfort and energy performance; it engages and upskills construction professionals to adopt and deliver higher performance targets for retrofit projects. It is aimed at those wishing to create high-performance buildings using widely available technology. Individual self-builders and large-scale residential and non-residential developers could make a valuable contribution to low-carbon building by meeting the AECB Building Standard.

The AECB Buildings Standard includes the: Building Standard & Certification; Retrofit Standard; Lifetime Carbon Standard; Water Standard; Daylight Standards. They also have a Low-Energy Building Database available on their website.

### [FCBS CARBON](#)

### FCBS CARBON

FCBS CARBON is a whole life carbon review tool, designed to estimate the whole life carbon of a building to inform design decisions prior to detailed design. This makes potential carbon impacts clear to the client, Architect, and the whole design team from the outset of the design process. Using benchmarked data from the ICE Database and EPDs, the tool is designed to give the design team insight into the whole life carbon impact of a building from the very outset of a project.

### [Royal Institute of British Architects \(RIBA\) Whole Life Carbon \(WLC\) Assessment](#)



Undertaking WLC assessments is recommended for all architects who wish to understand and minimise the carbon emissions associated with their designs over the entire life cycle of the building. The WLC assessment is a detailed methodology for calculating the embodied energy and whole life carbon of a building.



## LEGISLATION & ASSESSMENT TOOLS

The knowledge gained from WLC assessments further enables architects to take the lead in sustainable design and construction.

Increasingly, clients in all sectors are commissioning WLC assessments as part of the project requirements, which is driven by its potential environmental, and also economic, benefits.

### Passivhaus

Passivhaus is an energy performance standard that was developed in Germany in the early

1990s. The approach dramatically reduces the requirement for space heating and cooling. This is primarily achieved by adopting a fabric first approach to the design, specifying high levels of insulation to the thermal envelope with exceptional levels of airtightness and the use of whole house mechanical ventilation. The Passivhaus Standard can be applied not only to residential dwellings but also to commercial, industrial and public buildings.



### BREEAM

BREEAM sets the standard for best practice in sustainable building design, construction and operation and has become one of the most comprehensive and widely recognised measures of a building's environmental performance. It is mainly used for non-residential development.



Energy Performance Certificates (EPCs) give information on how to make your home more energy efficient and reduce carbon dioxide emissions. Display Energy Performance Certificates showing operational energy in use are required for all public buildings.

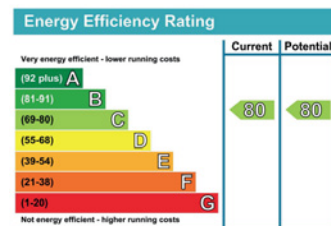

## LEGISLATION & ASSESSMENT TOOLS



**Case study:** Bath Western Riverside. The first phase of Bath Western Riverside is being built to Code for Sustainable Homes level 4 and includes measures such as district heating, brown roofs and state of the art insulation.

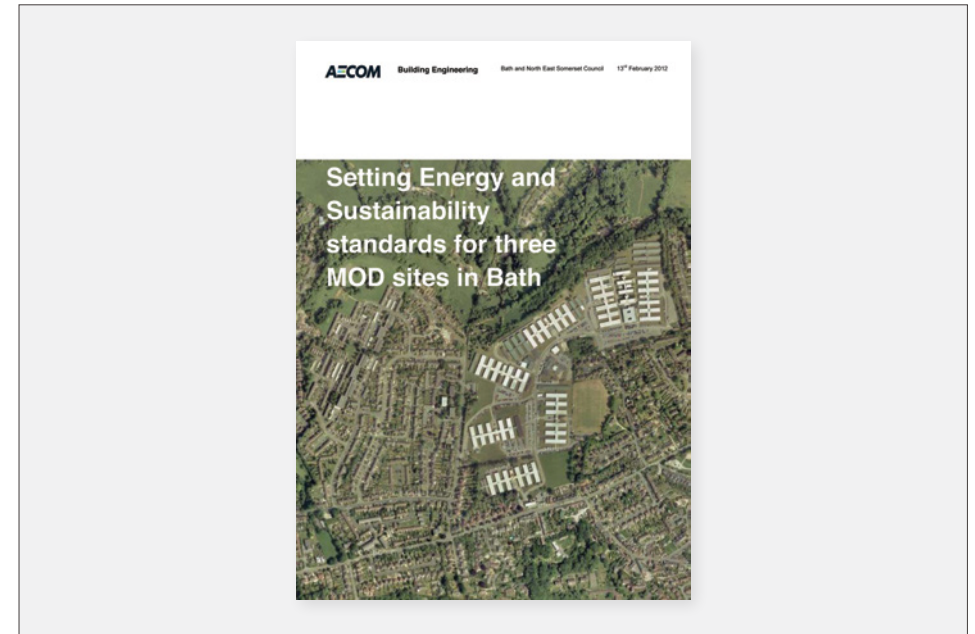

**Case Study:** Ministry of Defence Sites. In Bath, The Council has set out its aspirations for higher Sustainable Construction standards in its Concept Statements for the former Ministry of Defence sites.



## **CASE STUDY: THE NUCLEUS AT HAYESFIELD GIRLS' SCHOOL, BATH**

Completed in 2012, this new building is super-insulated, passively designed and built using pre-fabricated renewable, locally sourced, carbon sequestering materials.

### **Land-Use and Ecology**

Raised habitat beds and new nesting areas for birds, bats, hedgehogs and insects are provided. Located on an existing area of hardstanding and built way from existing trees.

### **Siting & Orientation**

The building has been designed to be PV ready and the roof includes containment and solar orientation for the later inclusion of PV cells. The siting away from existing trees prevents shading which may otherwise compromise the performance of the future PV.

### **Passive Design**

Careful siting and orientation reduces excessive solar gain. An efficient layout of spaces to ensure a low-surface-area to volume ratio increasing the building's thermal performance.



### **Thermal Mass**

Thermal mass provided by the straw bale construction is complemented by a night time cooling strategy. Careful location and sizing of glazing, and solar shading helps to regulate temperatures. Deep window reveals and external shading are included at the south and west elevations.

## CASE STUDY: THE NUCLEUS AT HAYESFIELD GIRLS' SCHOOL, BATH

### Surface Water Run-Off

Permeable paving surfaces around the building help prevent excess run-off during heavy rain. Rainwater is diverted to a new soakaway in the adjacent playing field.

### Energy

**Embodied energy** – The timber and straw superstructure has sequestered 376 tons of atmospheric carbon dioxide.

**Operational energy** - Low energy light fittings are used with motion and daylight sensors. Energy, environmental and weather monitors in and around the building have been installed provide data that can be studied as part of the science curriculum. Realtime data displays allow students to understand the carbon emissions from the buildings.

The building is heated using a highly efficient gas condensing boiler. The building uses a mix mode system of mechanical and natural ventilation: all teaching spaces are designed to provide closecontrolled natural ventilation whilst a mechanical ventilation heat recovery system can be used to minimise heat loss in the winter months.

### Materials

Materials with low embodied carbon and a high recycled content were selected. Building materials included straw bales, grown and made at a farm just outside Bath, which form the super-insulated building envelope. This technology was developed at the University of Bath. The external furniture is produced from oak planks responsibly sourced and recycled from a local building.

### Waste

Offsite prefabrication meant that onsite waste was greatly reduced during construction. The timber structure is digitally cut to minimise waste. Straw bale trimmings produced during manufacture were composted, used as bedding for farm animals or recovered as biomass.

### Link to full case study:

<https://www.modcell.com/projects/hayesfield-school-stem-centre-science-building/>

**CHAPTER 4:**  
ACHIEVING AFFORDABLE WARMTH

# HEATING AND HEALTH: THE AMBITION OF AFFORDABLE WARMTH FOR ALL

## What is it?

The term 'affordable warmth' relates to helping people on low incomes, in fuel-poor households, improve the energy efficiency of their home so that they can afford to keep their home warm.

The latest (2019) National Statistics estimate for B&NES is that 8,314, or 10.2%, of households meet the Government's new Low-Income Low Energy efficiency definition of fuel poverty. This compares to a South West estimate of 10.6% and an England estimate of 13.4%. The highest estimate of 17.5% was found in the West Midlands. The official criteria for this definition are as follows:

- Disposable income after housing costs and energy needs to be below the poverty line (the income poverty line defined as an equivalised disposable income of less than 60% of the national median).
- A fuel Poverty Energy Efficiency Rating (FPEER) of D, E, F or G where direct energy cost interventions such as energy bill rebates are taken into account. This is then translated into a Band (from A to G).

## Why is this important?

It is the combination of low incomes and low home energy efficiency ratings which means these households are less likely to be able to afford the cost of adequate home heating. As such, they are also at a great risk from the associated health and quality of life impacts of a cold home.

Existing physical health conditions can be made worse, there is a significant potential for deteriorating mental health and lower overall wellbeing, and there are other effects such as social isolation and lower educational attainment. Many affected households in B&NES include dependent children, and people with long-term disabilities or illnesses.

A staggering proportion of excess winter deaths are attributed to a cold home, and a significant proportion of them are a direct result of fuel poverty. Therefore, enabling everyone to achieve affordable warmth has the potential to help address excess winter deaths.

# HEATING AND HEALTH: THE AMBITION OF AFFORDABLE WARMTH FOR ALL

## **B&NES' housing stock**

Analysis of the housing stock in B&NES, at an individual property level, shows that households across all house types, as well as all tenures, meet the Government's fuel poverty definition, with the exception of late 20<sup>th</sup> century homes (Housing stock condition model produced by the BRE in 2016).

### **Further Guidance:**

- The official definition of Fuel Poverty is set out in the Government's Sustainable Warmth strategy published in February 2021.
- Fuel Poverty in the UK

# HOW TO ACHIEVE LOW-CARBON AFFORDABLE WARMTH

## B&NES Council's Role

Achieving affordable warmth also presents an opportunity to reduce carbon emissions through utilising cheaper renewable sources of energy and burning less or zero fossil fuel. B&NES Council aims to help low income households achieve affordable warmth using Council and Government funding to assist with energy efficiency and low-cost low carbon heating improvements. Our aim is that all households achieve the Government target of an energy efficiency rating band C wherever reasonably practical.

As a Planning Authority, Bath and North East Somerset Council have a unique role to play in promoting energy efficiency and renewable low carbon heating with a planning policy which encourages home energy upgrades for households who cannot achieve affordable warmth. This includes those living in heritage buildings. This Energy Efficiency Retrofitting & Sustainable Construction SPD aims to provide clarity on:

- what improvements to make;
- whether planning or listed building consent is required; and
- what is necessary for consent for essential affordable warmth upgrades to take place.

All house types typically found in B&NES – other than the only exception of recently-constructed, late-Twentieth-Century house types – require energy efficiency and low-carbon heating retrofit to achieve the Council's affordable warmth and zero carbon goals.

## Available Solutions

### B&NES Energy at Home

The Council provides information on how to carry out and finance home energy retrofit on our Energy at home website, by email and telephone. The latest information on affordable warmth grants for B&NES residents can also be found here:

Website: [www.energyathome.org.uk](http://www.energyathome.org.uk)

## HOW TO ACHIEVE LOW-CARBON AFFORDABLE WARMTH

Email: [energyathome@bathnes.gov.uk](mailto:energyathome@bathnes.gov.uk)

Telephone 0800 038 5680/ 01225 396444

B&NES Council usually has one or more schemes running to assist households achieve low-carbon affordable warmth. Details of these can be found by visiting the B&NES Energy at Home website, or emailing or phoning the information and signposting service using the contact details above.

The Affordable Warmth help schemes and grants currently available include:

- B&NES Green Affordable Warmth Grant
- West of England Affordable Warmth Grant from the South West Energy Hub
- B&NES Low cost energy loan from Lendology

The Council also provides ECO flex declarations for eligible residents to enable suitable contractors working in the area to reduce the cost of measures installed. Further details about Flexible Eligibility are set out in

our ECO Flex statement available on the Council's Housing Services web pages.

It is important to note that the availability of the Affordable Warmth help schemes mentioned above may be subject to change in terms of both eligibility and availability over time. We encourage you to check the Energy at Home website, or contact the LPA, for the latest information.

**CHAPTER 5:**  
FURTHER INFORMATION



## FURTHER INFORMATION

### An Introduction to the Different Housing Types in B&NES

#### Our Homes

Bath & North East Somerset is fortunate to have a wealth of historic and modern homes. Traditional and Modern buildings are quite different structurally and different techniques and materials are used in their construction. It is often assumed that the older a building is the less energy efficient it will be. However, research shows that this is often not the case. Historic buildings were often designed when energy was expensive, whereas twentieth century buildings are often among the most inefficient. Key features of traditional construction are: thick solid walls, natural ventilation, and the use of natural breathable materials. Modern construction techniques are more likely to include: cavity walls, tightly controlled ventilation and the use of cement and plastics. After 1985, Building Regulations include energy as a consideration and since then increasingly energy efficient construction techniques are being used.

#### Our Approach

In this section, the five most common house types in Bath & North East Somerset are introduced. It is important to understand how your building is constructed, how it functions as well as how you use it when you are thinking about how best to save energy and water in your home. Section drawings are included to help illustrate key points.

The information should help you to diagnose:

- What are the main environmental issues for your house type?
- What are the main retrofitting opportunities for your house type?

**Chapter 2** introduces, and provides guidance on, a range of retrofitting measures.

## Buildings of a Traditional Construction



17<sup>th</sup> Century Detached Cottage



Georgian Townhouse



Victorian/Edwardian Terrace

## Buildings of a Modern Construction



Early Modern 1930s Semi-Detached



Late Modern Post 1985 New Build

# 17<sup>TH</sup> CENTURY BUILDING



Section drawing of a typical 17<sup>th</sup> Century house in Bath & North East Somerset

## 17<sup>TH</sup> CENTURY BUILDING

Ensuring your building is in a good state of repair will be critical to optimising its energy efficiency. Poor or inappropriate maintenance can lead to excess draughts, damp problems and condensation which will damage the building and increase energy bills.

### Typical Issues:

**1.** Small windows and deep reveals mean that natural light levels are quite low and more internal lighting is needed. However, small windows particularly on the north side can also help reduce heat loss.

Windows on the upper floors are often set closer to the floor, which can lead to draughts.

**2.** Windows are normally singleglazed leaded lights which are thermally poor with simple iron casements that can be a source of draughts unless close fitting.

**3.** Stone tile roof coverings are particularly draughty, and many will not have roof underlay. Mortar fillets can prevent the junctions between the roof and gable wall from being draughty if kept in good repair.

**4.** Plastered sloped parts of the ceiling such as the underside of the roof (known as skellings) are unlikely to be insulated and accessing these cavities can be troublesome without removing fabric internally or externally. Thick timber purlins can make insertion of insulation between rafters particularly difficult.

**5.** Large open fireplaces are good for burning wood (a renewable resource) but allow heat to be lost up the chimney. The larger flue sizes can also be a significant source of draughts.

**6.** Traditional timber partitions (completely wooden walls made up of beams and infill planks) or timber stud partitions between rooms allow heat to transfer within the building and make heating to different temperature zones harder. The heat from your living spaces may be lost to rooms not being used!

**7.** Uninsulated ground bearing flagstone floors lose heat from the interior, but their moisture permeability (breathing) can be adversely affected by insulation, increasing the likelihood of rising dampness in the walls.

**8.** Large timber beam ends inserted in the masonry walls can introduce cracks through which colder air can penetrate the building.

**9.** Stout masonry walls, ground bearing floors and large timbers all provide good thermal mass – however this can be slow to respond to swift changes in the weather or intermittent usage of rooms.

The high thermal mass does reduce the need for summer cooling of the building but poor insulation at roof level can lead to rapid heat gain in summer and heat loss in winter.

**10.** Small modular rooms can help retain heat in parts of the house in use and can be more efficient than modern open plan arrangements.



# GEORGIAN/18<sup>TH</sup> CENTURY BUILDING

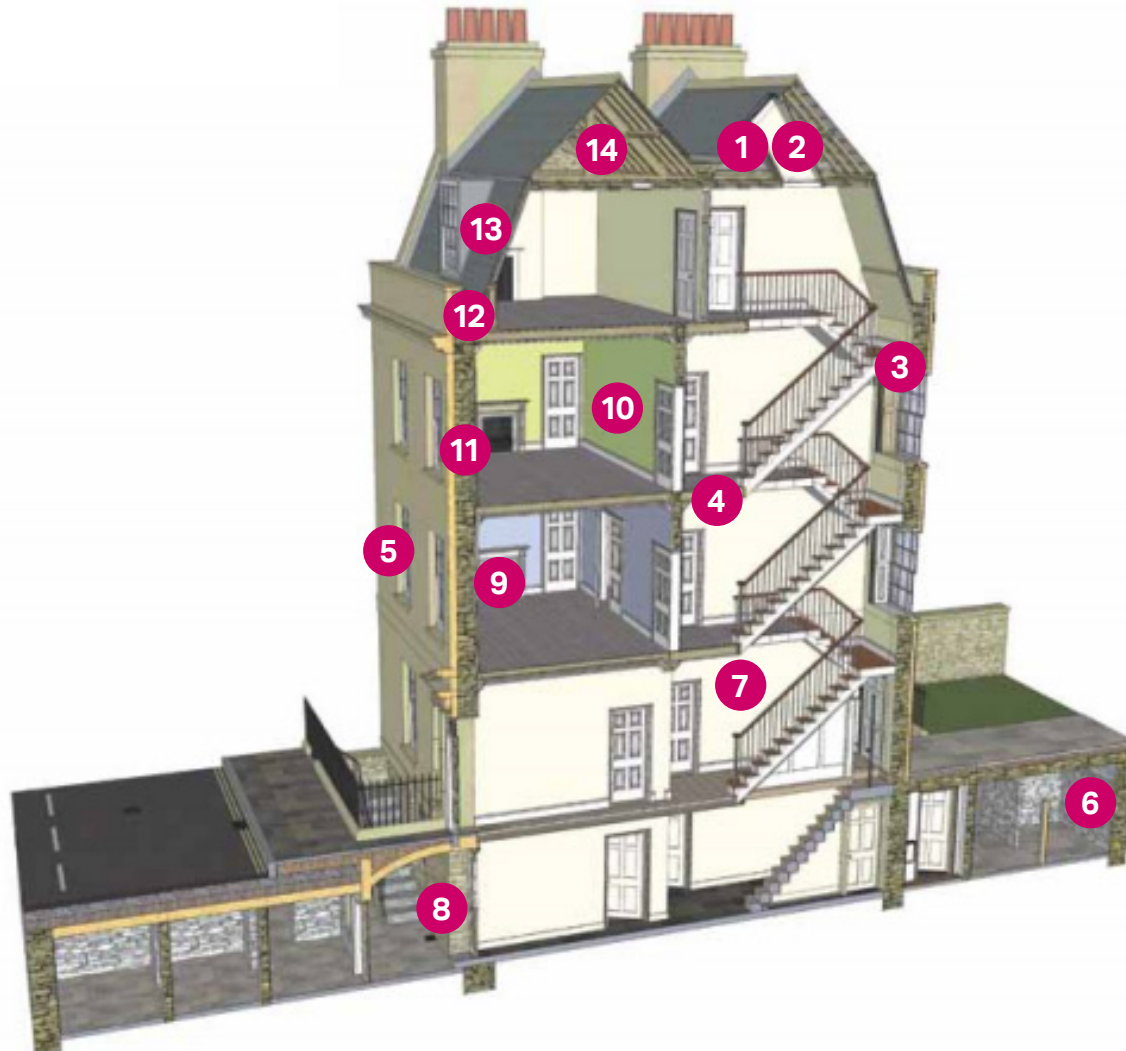

Section drawing of a typical 18<sup>th</sup> Century Georgian house in Bath & North East Somerset.



Example of a typical 18<sup>th</sup> Century Georgian house in Bath & North East Somerset.

## GEORGIAN/18<sup>TH</sup> CENTURY BUILDING

Ensuring your building is in a good state of repair will be critical to optimising its energy efficiency. Poor or inappropriate maintenance can lead to excess draughts, damp problems and condensation which will damage the building and increase energy bills.

### Typical Issues:

1. Parapet and valley gutters drain via through-channels which require openings to the roof space and introduce cold bridging and condensation risks.
2. Roof windows and light wells are often poorly performing thermal elements but improve natural light levels to the interior. They can also be useful for natural stack ventilation.
3. Suspended timber upper floors built into the external walls introduce numerous cracks or fissures through which cold air can penetrate the building.
4. Internal floors and partitions are uninsulated, and heat can easily transfer from room to room.
5. Large single-glazed sliding sash windows should be put in good repair to eliminate draughts; also ensure timber shutters operate well as they can provide valuable insulation at night or when the room is not being used.
6. Vault spaces have poor levels of light and ventilation, but their earth-sheltered arrangement can be a useful thermal buffer to the habitable rooms at basement level.
7. A large open stairwell and hall can quickly dissipate heat and be hard to keep warm. Keeping internal doors closed will help.
8. External doors often contain slender timber panels and single glazed fan-lights which readily allow heat transfer.
9. Numerous fireplaces and flues allow heat to be lost up the chimneys and draughts to enter the building. However, they also ensure good ventilation and indoor air quality.
10. Taller room heights and generous windows allow good levels of natural light and ventilation.
11. External walls are typically quite slender, particularly on the upper storeys, and heat is lost through solid masonry.
12. Parapet gutters should be insulated to minimise cold bridging through the thin lead and timber linings.
13. Upper floor rooms are typically uninsulated lightweight construction; skellings, dormer cheeks and roofs will require improvement to their thermal performance.
14. Roofs are often uninsulated and roof voids can sometimes be small or hard to access.

# VICTORIAN/EDWARDIAN BUILDING

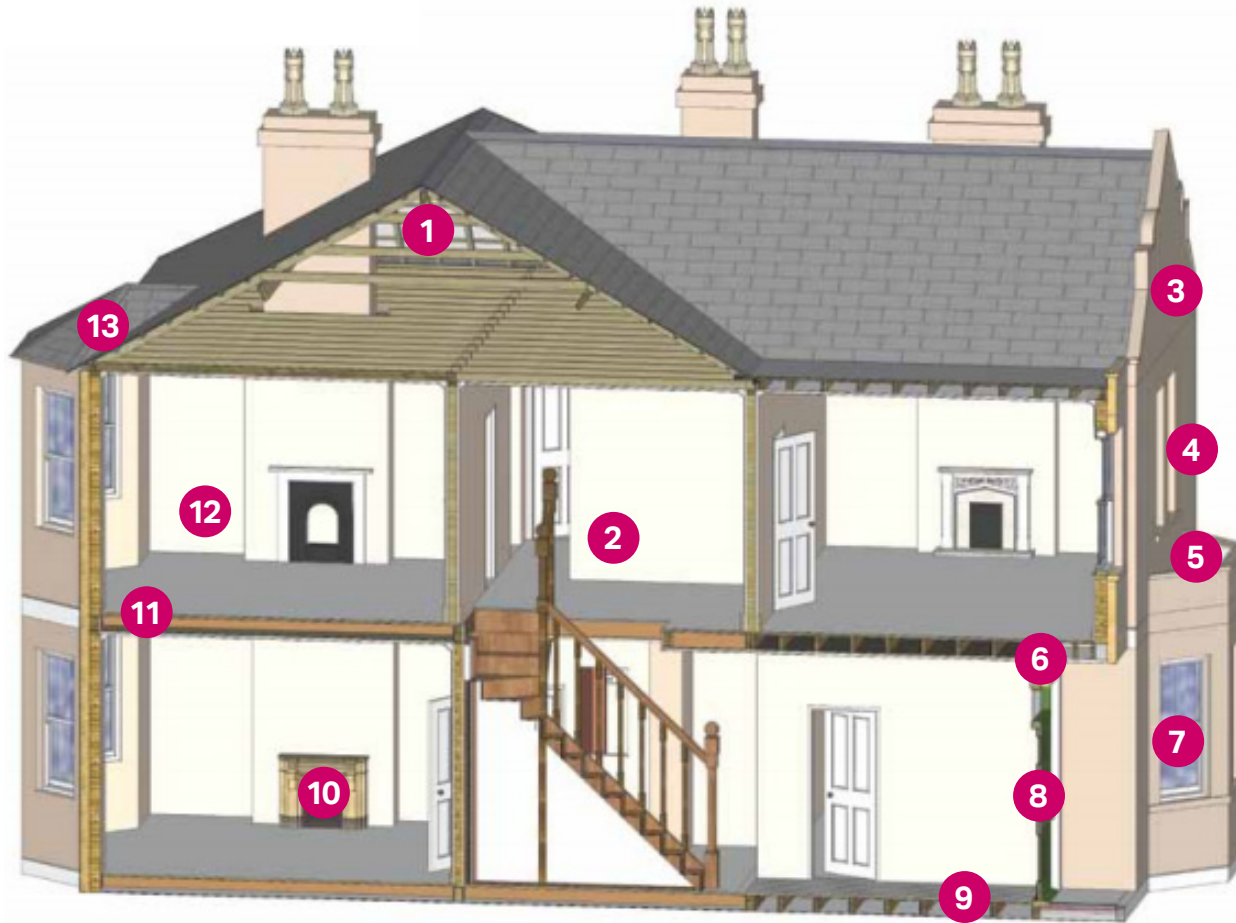

Section drawing of a typical Victorian/Edwardian house in Bath & North East Somerset



Example of a Victorian/Edwardian Building in Bath & North East Somerset



## VICTORIAN/EDWARDIAN BUILDING

Ensuring your building is in a good state of repair will be critical to optimising its energy efficiency. Poor or inappropriate maintenance can lead to excess draughts, damp problems and condensation which will damage the building and increase energy bills.

### Typical Issues

- 1.** Roofs are uninsulated and roof coverings were laid without roof underlays, making heat loss and draughts an issue.
- 2.** An open stairwell and hall can quickly dissipate heat and be hard to keep warm. Keeping internal doors closed will help.
- 3.** Gable walls and those to outhouses may be quite slim. four-inch-thick walls perform particularly poorly thermally. Purlins and joists built into these slender walls can also reduce the performance further, introducing air-paths for draughts.
- 4.** External walls are typically quite slender, and heat is easily lost through the solid masonry
- 5.** Roofs to bay windows can be difficult to insulate, and often present a cold bridge for the building.
- 6.** Internal floors and partitions are uninsulated, and heat can easily transfer from room to room.
- 7.** Single-glazed sliding sash windows should be put in good repair to eliminate draughts. Where present, ensure timber shutters are in working order as these can provide useful insulation at night or when the room is not being used.
- 8.** External doors often contain slender timber panels and single-glazed overlights which readily allow heat transfer.
- 9.** Suspended timber ground floors have ventilated spaces beneath which can raise draughts through the boards and floor edges.
- 10.** Fireplaces and flues allow heat to be lost up the chimneys and are routes for draughts to enter the building.
- 11.** Suspended timber upper floors built into the external walls introduce numerous fissures or cracks through which cold air can penetrate the building.
- 12.** Tall room heights and multiple windows, including those set-in bays provide high levels of natural light and ventilation but can be a source of heat loss.
- 13.** Dwarf roofs to bay windows can be difficult to insulate due to limited accessibility.

# EARLY 20<sup>TH</sup> CENTURY BUILDING

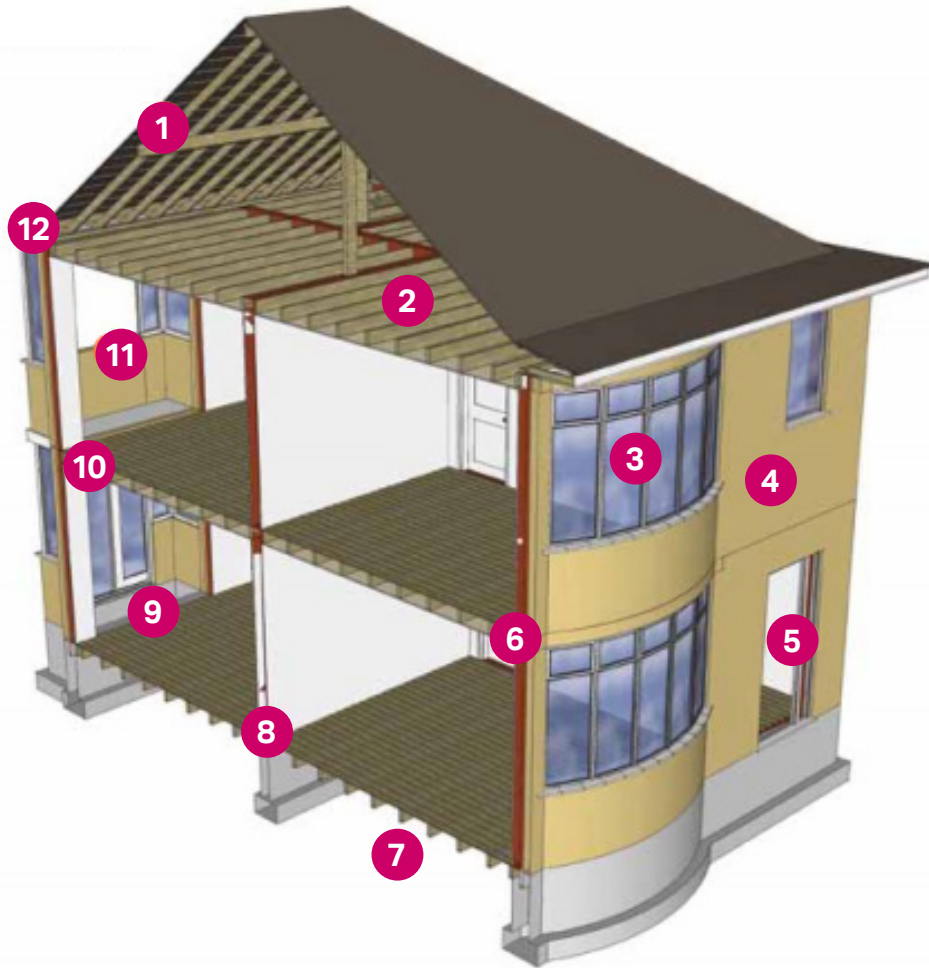

Section drawing of a typical 1930s Semi-Detached house in Bath & North East Somerset



Example of an Early 20<sup>th</sup> Century Building in Bath & North East Somerset

## EARLY 20<sup>TH</sup> CENTURY BUILDING

Ensuring your building is in a good state of repair will be critical to optimising its energy efficiency. Poor or inappropriate maintenance can lead to excess draughts, damp problems and condensation which will damage the building and increase energy bills.

### Typical Issues

- 1.** Party walls at roof space can be incomplete, allowing heat transfer and air movement between properties.
- 2.** Roofs are uninsulated and roof coverings were laid without roof underlays, making heat loss and draughts an issue.
- 3.** Original large 'picture' windows with single glazed metal framed casements in timber surrounds have very poor thermal performance. Wall cavities were not closed at openings.
- 4.** External walls are typically quite slender, and heat is easily lost through the solid masonry. Early cavity walls often contain rubble particularly at lower level making them difficult to insulate without causing cold bridging. Un-insulated cavity walls have a superior thermal performance to traditional solid walls but are still poor compared to modern building standards.
- 5.** External doors often contain slender timber panels and single-glazed side screens which readily allow heat transfer.
- 6.** Internal floors and partitions are uninsulated, and heat can easily transfer from room to room.
- 7.** Suspended timber ground floors have ventilated spaces beneath which can raise draughts through the boards and floor edges.
- 8.** Draughts can easily enter building at junctions between floors and walls.
- 9.** Fireplaces and flues allow heat to be lost up the chimneys and draughts to enter the building. Air bricks connecting rooms provide further routes for heat loss.
- 10.** Suspended timber upper floors built into the external walls introduce numerous fissures or cracks through which cold air can penetrate the building.
- 11.** Tall room heights and multiple windows, including those set-in bays, provide high levels of natural light and ventilation but can be a source of heat loss.
- 12.** Roofs to bay windows can be uninsulated concrete with asphalt coverings, so being a source of heat loss.

# LATE 20<sup>TH</sup> CENTURY BUILDING

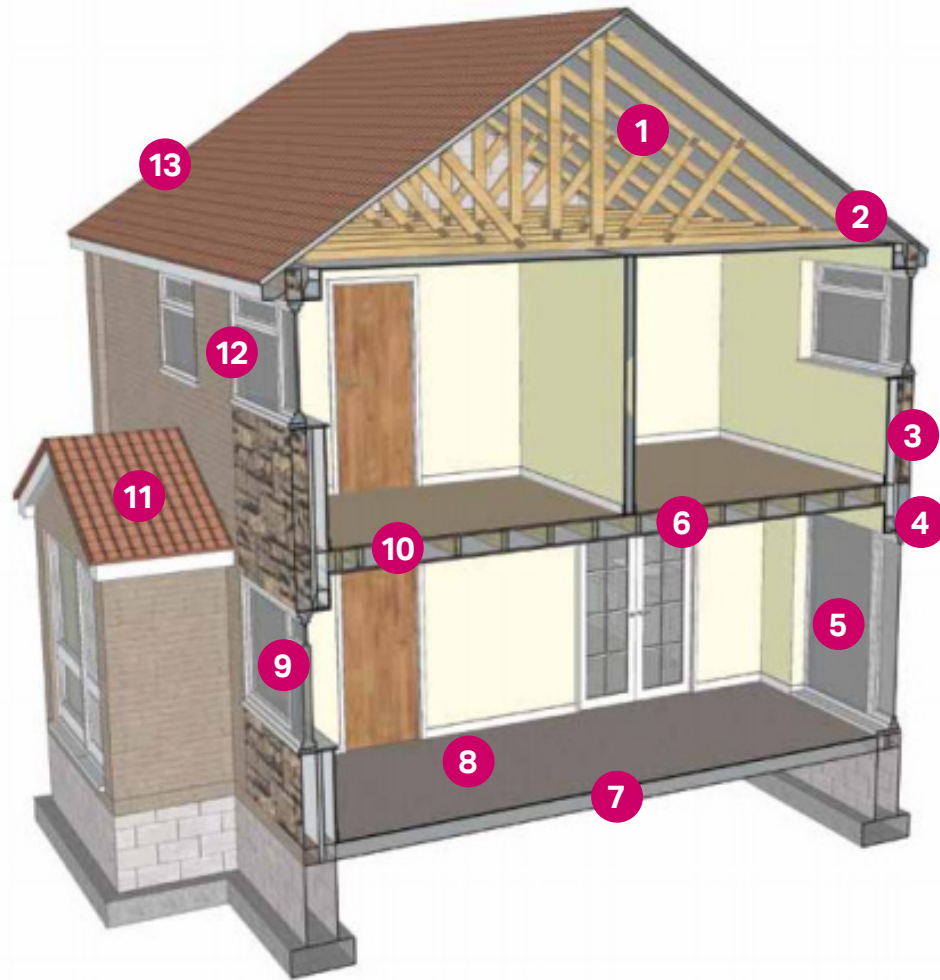

Section drawing of a typical Post 1985 House in Bath & North East Somerset



Example of a Late 20<sup>th</sup> Century Building in Bath & North East Somerset

## LATE 20<sup>TH</sup> CENTURY BUILDING

Ensuring your building is in a good state of repair will be critical to optimising its energy efficiency. Poor or inappropriate maintenance can lead to excess draughts, damp problems and condensation which will damage the building and increase energy bills.

### Typical Issues

- 1.** Slender trussed rafter roofs may require strengthening to accommodate roof mounted renewable energy systems.
- 2.** Roof space is likely to be 'cold', with some loft insulation likely to be present at ceiling level only. The roof requires ventilation to dissipate humidity which rises from the living spaces below. Cold bridging is common at the eaves, where insufficient insulation depth is present, and an air path is required for ventilation.
- 3.** External masonry cavity walls are uninsulated although have thermally efficient blockwork to the inner skin. Wall cavities are closed with masonry at perimeters and openings, forming cold bridges.
- 4.** Uninsulated steel building lintels are typical, locally reducing thermal performance of external walls at door and window heads.
- 5.** Large patio doors are common, with low grade airfilled, small cavity, double glazing. UPVC or aluminium doors are not likely to be thermally broken – allowing heat transfer through their frames.
- 6.** Internal floors and partitions are uninsulated, and heat can easily transfer from room to room.
- 7.** Uninsulated ground-laid concrete floor slab set above external ground level acts as thermal bridge to transfer heat.
- 8.** Inefficient 'flame effect' gas fires common to living room, served by class 2 flue.
- 9.** Windows typically softwood with air-filled, small cavity, double glazing that are not substantially more efficient than older window types.
- 10.** Suspended timber upper floors built into the external walls introduce numerous fissures or cracks through which cold air can penetrate the building.
- 11.** Porch roof and walls likely to be of lower thermal performance than rest of building so can be a source of heat loss.
- 12.** Windows with minimal openings for ventilation and increased air tightness of building envelope means mechanical ventilation is required to extract humidity from kitchen and bathrooms.
- 13.** Gas fired central heating with wall mounted boilers and hot water storage tanks are typical of the low efficiency installations originally fitted.



## WHAT MAKES A GOOD LISTED BUILDING APPLICATION?

General guidance on listed buildings and Consent applications is available on our website, as follows:

- [Listed Building Consent - Application Form](#)
- [Listed Building Consent - Checklist](#)
- [Listed Building Consent - Guidance Note](#)
- [Listed Building Consent - FAQs](#)

As well as reading this guidance it is important to engage with the Historic Environment Team at an early stage, to establish whether or not the LPA can support the proposals and if so the most appropriate approach to take.

This will usually require engagement with the formal pre-application process for which there is a charge, however its benefits cannot be overstated and can, in principle support can be provided, lead to a successful scheme and outcome.

When applying for Listed Building Consent for energy efficiency or renewable energy measures, there are a number of particular considerations. These

predominantly relate to the level of impact, if any, on the architectural and historic interest of the protected building.

Designation is a formal and legal acknowledgement of a building's architectural and historic interest and national significance and importance. However, some change is inevitable, and the LPA will work with listed building owners to manage this change and identify ways to meet the needs of occupants wherever possible although the level of change is likely to differ significantly from one building to another and each building will be assessed on a case-by-case basis and each building on its own merits.

Whilst anyone can apply for listed building consent in reality it requires specialist skills, knowledge and experience and therefore listed building owners are strongly advised to instruct a conservation specialist architectural professional to assist them (i.e. a surveyor, architect or architectural technician). The LPA has a limited list of conservation specialists and this can be provided if required (contact a member of the Historic Environment Team for more information).

## WHAT MAKES A GOOD LISTED BUILDING APPLICATION?

The increasing focus on energy efficiency and renewable energy in recent years has led to a huge increase in the number of applications for improvement measures in listed buildings. This brings complexities as well as benefits, and it is important that applications are as clear as possible. When submitting your application, there are a number of things that need to be considered.

### 1. Research

For many energy efficient measures, there can be a bewildering array of choices available. Spend time early on researching all the options available to you, and make sure the application reflects this and shows exactly why you have selected the system in question.

You should make it as easy as possible for the LPA to assess your application. Doing your research also extends to choosing the right person or organisation to give you the professional support you will need, e.g. architects, surveyors or contractors – make sure you use someone who really understands both the energy and conservation aspects of your application but most importantly they understand and are experienced in architectural conservation. It is important to be aware and have knowledge of the relevant specialist guidance, much of which has been produced by English Heritage and is available on the internet (see section 6 of this document).



# WHAT MAKES A GOOD LISTED BUILDING APPLICATION?

## 2. Detail

Provide as much detail as possible about the particular technology you want to install. The type of draught proofing, double glazing or solar panel will determine its impact on the building – again, demonstrate that you have done your research and selected the system most sensitive and sympathetic for the building and, if relevant, for the setting of the conservation area and, in the case of Bath, the World Heritage Site.

Remember that for many improvement measures there are solutions available that are both effective and discreet, although some may require additional scoping works (e.g. a structural survey of a roof where solar panels are proposed to take account of the additional weight).

Specifications, drawings and photographs are all helpful to the LPA, and photo-montages showing the likely appearance post-installations are also useful. If in doubt, provide more rather than less detail in the application.

## 3. A Practical Approach

The communication of a practical, common-sense and sensitive approach will be expected. Showing that you have considered or adopted passive and low impact measures is important and consistent with the hierarchical approach. For example, proposing a heat pump, external and internal insulation in the first instance, having not considered and implemented simple draft exclusion or replacing a gas central heating boiler with an efficient modern combination boiler would not be in line with energy hierarchy unless there were other factors in terms of impact on historic fabric you are considering.

## WHAT MAKES A GOOD LISTED BUILDING APPLICATION?

### 4. Location

For more visual measures (solar panels, air source heat pumps, boiler flues, external wall insulation etc, demonstrate that you have thought about their impact on the building's and, where relevant, the conservation area's appearance and setting and what considerations have been taken to minimise the impact. Be sure to locate them in a discreet position. The 'Guidance on measures for listed buildings' section of this document provides numerous examples of this.

### 5. Loss of Historic Fabric

Loss of significant historic building fabric is seldom regarded as acceptable and is inconsistent with the aims of heritage protection as enshrined in the primary legislation, national policy and guidance relating to the historic environment. However there may be some circumstances where the temporary removal of historic fabric may be regarded as justifiable. The Historic Environment Team should be consulted in order to provide advice and clarification.

### 6. Precedence

Precedence is not a determining factor in assessing changes to listed buildings – i.e. a measure approved on one building may not be deemed appropriate for another. Each application is assessed on its own merits, and this can mean that seemingly similar proposals for similar buildings do not always receive the same outcomes. However, it can be helpful to show the LPA some examples of what you are proposing to help illustrate your application where this has been successfully applied on other buildings.

### 7. Appropriateness

For higher-impact measures in particular it is important to explain and justify clearly why you feel they are needed for your property. Remember, while you may have a focus on saving energy, reducing your carbon footprint and CO2 emissions or making your house warmer, the LPA will assess the application based on its physical and visual impact on the architectural and

## WHAT MAKES A GOOD LISTED BUILDING APPLICATION?

historic interest of the listed building and on the setting of the conservation area and other heritage assets where this is relevant.

Therefore, it will be expected that stronger justification will be required in the case of higher impact measures: the greater the impact, the greater the justification that will be required. It will also be expected that relevant guidance has been consulted and that the proposals are consistent with the approach advocated by the guidance and with conservation best practice.

## LOCAL HERITAGE ASSET CASE STUDIES

The following case studies provide examples of detailed applications for Listed Building Consent, demonstrating good practice both in the level of detail provided and in the initial consideration of measures. You will see that not all of the proposed measures were well received; however these also provide useful case studies for potential applicants. Please note that all planning and listed building applications are available for public [viewing online](#).

## LOCAL HERITAGE ASSET CASE STUDIES



- A) New slim-profile double-glazed windows in Grade I listed building. St John's Hospital, Bath City Centre.**

### **Key elements of this application:**

#### **An appropriate intervention**

The original windows were no longer in place, and the current windows did not match the originals so this represented a good opportunity to bring back the original window designs while upgrading the thermal performance to modern standards which is particularly important given this building's function. Double glazing was demonstrated to be preferable to secondary glazing and blinds/ curtains in this instance, due to the importance of daytime thermal comfort and ease of use for occupants.

## LOCAL HERITAGE ASSET CASE STUDIES

### **Drawings**

Detailed, professional scale drawings showing current and proposed building details. These are available online.

### **Supporting materials**

Detailed, clearly laid out and explained, demonstrating a thorough knowledge and relevant research. The covering letter and Design Statement show an understanding of both key aspects of the application, a) built heritage (of the building and its setting) and b) energy conservation. Referencing to previous installations and research are clear and thorough Additional detailed written response to English Heritage advice.

### **LPA feedback**

Noted that the building was very prominent both in style and location, and that there may be some visual impact from replacing single glazing with double glazing; but also, that other energy efficiency measures had already been carried out; that the current windows were not original and that the new windows would help bring back original window designs

### **Other feedback**

External feedback was mixed. Bath Preservation Trust noted that a whole-building approach was less intrusive than a partial approach, and that 'public benefits of mitigating climate change outweigh concerns about visual appearance of the glass'. Bath Heritage Watchdog objected to the proposal, however, feeling that 'single glazing forms part of the interest of a listed building and should be retained to preserve the integrity of the building'.

### **Outcome – Approved**

## LOCAL HERITAGE ASSET CASE STUDIES



**B) New slim-profile double-glazed units in Grade II listed building. Tunley Farmhouse, Tunley Hill, Camerton.**

**Key elements of this application:**

**An appropriate intervention**

The existing windows were not original, were in a poor state of repair and needed replacing; the proposed new windows matched the design of the originals. The proposed works would also go some way to remedying a lack of planning enforcement on adjacent properties that had adversely affected the property in question. However, it should be noted that the original proposal for double glazing of standard (20mm) cavity width was re-negotiated to slim-profile double glazing, which lengthened the timescale for granting consent to seven months.



## LOCAL HERITAGE ASSET CASE STUDIES

### **Drawings**

Detailed drawings showing current and proposed building details  
Supporting materials – Clear, simple explanations of why the proposed works are needed.

### **LPA feedback**

The LPA felt that the original proposal for 20mm cavity double glazing would have been harmful to the property's character and appearance and re-negotiated to slim-profile double glazing

### **Other feedback**

The local parish council supported the application, highlighting the lack of planning enforcement in neighbouring properties.

**Outcome - Approved** but with a change from standard-depth to slim-profile double glazing.

# LOCAL HERITAGE ASSET CASE STUDIES

**Bath Homes** fit for the future

## Georgian / Regency Terrace, Bear Flat



**Overview**

Age/Period: 1750/1811 - Georgian/Regency, Grade II listed  
Type: 3 storey terrace  
Years in residence: 43  
No. Bedrooms: 5  
Wall type: Solid wall, Bath stone Ashlar

**Key Features**

- Solar PV (on Grade II listed)
- Loft Insulation
- Secondary Glazing
- Draught Proofing
- Zoned Heating Controls
- Radiator Reflectors
- Low Energy Appliances

**Introduction**

John and Pat Tofts have lived in their attractive Grade II listed terrace home for 43 years and have always taken a DIY approach to making their home warmer and greener. They have fitted home-built seasonal secondary glazing units to most of the windows and fitted their own draught proofing, radiator reflectors and loft insulation. More recently solar PV panels were installed to the roof valley to help compensate for the rising cost of electricity and to reduce their carbon footprint. They have changed their domestic habits to take advantage of the free electricity that is generated during the day and earned £360 from the government's Feed-in Tariff in the first 18 months.

**Features**

**Secondary Glazing**  
Over 20 years, John has built his own secondary glazing units and fitted them to most of their windows, including a stained glass semi-circular feature window. He has experimented with different materials and fittings and examples can be seen that are made of glass, Perspex, and glazing film. The secondary glazing, not only reduces heat loss and draughts through the old sash windows, but improves acoustic insulation that reduces traffic noise in the house.

**Solar PV**  
John and Pat had originally looked into installing a solar hot water system, though it was ruled out due to the disruption that would be caused by the need for a new dual-coil hot water tank and new piping to be run through their 3 storeys. This was the first Grade II listed home in Bath to be granted planning permission for solar PV panels on the roof. John said 'to obtain Listed Building consent, we had to prove that the installed PV panels could not be seen from anywhere external to the building. In addition, we had to confirm that we had considered all of English Heritage's criteria set out in their publication, 'Microgeneration in the Historic

*"We try to use electrical appliances when the sun is shining to use our 'home-made electricity'. With the cost of electricity rising, we think that this will be a good investment."*

## C) Photovoltaic panels on Grade II listed building. 19 Devonshire Buildings, Bear Flat.

### Key elements of this application:

#### An appropriate intervention

From a heritage perspective the siting is appropriate as it is discreet, with panels 'hidden' inside the double-pitched roof valley, external wiring run behind a downpipe to minimise visual impact, a board-mounted inverter to minimise fixings to original fabric, and a high position ensuring the roof is not overlooked. From an energy efficiency perspective, the siting is unfortunately less appropriate, as the requirement to hide the panels to minimise visual impact results in regular overshadowing by the roofline and chimney, causing sub-optimal performance – this is a good example of where heritage and energy conservation priorities can conflict. The installation was however combined with other energy-saving measures, demonstrating a holistic approach.

# LOCAL HERITAGE ASSET CASE STUDIES

## **Drawings**

Detailed drawings, clearly showing the location of the installations and the fixing details.

## **Supporting materials**

Clear, detailed explanations in support of the proposed works, demonstrating a good understanding of both heritage and energy conservation principles, an awareness of relevant legislation and guidance, a thorough approach that has included both heritage and energy-saving improvements, and clear reasons for proposing PV over other renewable energy technologies. Also, an illustration of conservation as 'management of change', detailing the changes that have taken place in the property over time.

## **LPA feedback**

Noted that there is 'no substantive reason for refusing consent in this particular case' but requires applicant to demonstrate that roof structure is sufficiently robust to carry weight of PV panels.

## **Other feedback**

One letter highlighted heritage issues and the need to assess roof structure.

**Outcome – Approved** subject to demonstrating that the roof structure would support weight of PV panels.

## LOCAL HERITAGE ASSET CASE STUDIES



**D) Photovoltaic panels on Grade II listed building.  
The Old Rectory, Newton St. Loe.**

**Key elements of this application:**

**An appropriate intervention**

As in case study C, the elevated position of the building and the panel location in a hidden roof valley ensures discretion. Furthermore, the applicant specified non-standard panel finishes to render them still more discreet.

# LOCAL HERITAGE ASSET CASE STUDIES

## **Drawings**

Detailed drawings and photographs, clearly showing siting and installation method.

## **Supporting materials**

A short but clear Design and Access Statement to accompany the drawings and photographs, highlighting the discreet panel finishes specified (black frames and backing sheets) and the intention to conduct a structural survey to ensure the roof's structural integrity is maintained.

## **LPA feedback**

Noted that 'appropriate conditions exist in order to facilitate solar panels', namely the hidden, internal roof valley, the parapet, the elevated position of the building and surrounding topography, and the minimal fixings and wiring required. Also stated a requirement to conduct the aforementioned structural survey.

## **Other feedback**

The local parish council supported the application. Bath Preservation Trust also supported the application, noting that there would be no adverse visual impact, and recommending that consent should be subject to proving the integrity of the roof structure and that other energy conservation works should also be carried out Duchy of Cornwall, 2012.

**Outcome – Approved** subject to satisfactory structural survey.

## LOCAL HERITAGE ASSET CASE STUDIES



**E) Refurbishment and extension of a Grade II listed building incorporating energy conservation measures. 7 Charlotte Street.**

**Key elements of this application:**

**An appropriate intervention**

Energy efficiency measures were proposed as part of a wider refurbishment and extension; this is a good time to consider such measures as other building works are taking place in any case. Proposed measures included draught proofing, shutter repairs, internal wall insulation, secondary glazing, slim-profile double glazing, roof insulation, solid and suspended floor insulation, gas central heating and a solar thermal array (sited on the principal elevation, but not visible due to the building's elevation and parapet). Pre-Application Advice was sought from the LPA before submitting the formal application. It should be noted that the secondary glazing and internal wall insulation were withdrawn from the application (for later re-submission) at the LPA's request. Drawings – Numerous very detailed drawings and photographs showing proposed works.

## LOCAL HERITAGE ASSET CASE STUDIES

### Supporting materials

A Design and Access Statement and Sustainable Construction Checklist were both submitted to provide details of all the proposed measures and reference local and national planning and climate change policy, together with other correspondence and reports throughout the assessment process. The formal reports also made use of modern energy analysis tools such as Energy Performance Certificate ratings, air pressure testing and thermal imaging to illustrate their proposals. Much of the midassessment dialogue related to certain improvements that were felt to be contentious, primarily the secondary glazing and internal wall insulation.

### LPA feedback

The LPA noted the need to upgrade the building to make it fit for habitation and supported the replacement of a poor existing extension with an improved version and the window replacements which they felt would enhance the property. They also felt the solar thermal evacuated tubes were acceptable. However, the LPA requested that the internal wall insulation and secondary glazing should be withdrawn from the application as they felt these measures would have a 'detrimental impact' on the building. (The applicant agreed in order to achieve a timely decision; these measures have since been re-submitted under a separate application.)

### Other feedback

An archaeologist provided groundwork recommendations. Bath Preservation Trust supported the proposed works including internal wall insulation where there was not significant plasterwork, and supported monitoring this measure for research.

**Outcome – Approved** following withdrawal of the internal wall insulation and secondary glazing measures from the application. A separate listed building application was submitted for these measures however was subsequently refused because they were deemed harmful and would not preserve the historic architectural interest and character of the protected building.



## LOCAL HERITAGE ASSET CASE STUDIES



### **F) Hydro turbine in a Grade II listed building. The Mill House, Midford.**

#### **Key elements of this application:**

#### **An appropriate intervention**

This building was constructed as a mill and had already been converted to generate electricity, however the current system was no longer functional; proposing a replacement hydro turbine is therefore entirely appropriate for this building and is in keeping with its original intended use. The introduction of a new hydro-electric turbine was proposed as part of a larger refurbishment project that included demolishing a modern structure and improving the other existing structures, and the project was discussed with the LPA through the Pre-Application Advice function prior to submitting the full application.

## LOCAL HERITAGE ASSET CASE STUDIES

### **Drawings**

Detailed drawings were provided including several detailing the proposed hydro turbine.

### **Supporting materials**

Comprehensive documentation was provided alongside the main application form, including a Design and Access Statement, a Heritage Statement, a hydro feasibility study report and broader environmental reports often required for hydro schemes (e.g. assessing wildlife and flooding impacts). The Design and Access Statement and the Heritage Statement both demonstrate a thorough understanding of the building's heritage; indeed, the hydro turbine is not portrayed as the prominent feature of this application. However, the hydro feasibility study clearly demonstrates the energy, CO<sub>2</sub>, and financial benefits of the turbine as well as the history of the earlier turbines.

### **LPA feedback**

The LPA was very supportive of the applicant's desire to retain the historic integrity of this 'significant' building And noted that the building already includes 'many layers of change and intervention over 700 years', that the proposals would preserve and enhance the building's significance. They were also supportive of the fact part of the proposals would see a modern structure removed and more traditional features reinstated and of the installation of the hydro turbine.

### **Other feedback**

An Ecology Officer provided comments on any environmental/wildlife impact, not relating to the hydro turbine Donald Insall Associates Ltd 2012.

### **Outcome – Approved**

# WHAT MAKES A GOOD LISTED BUILDING APPLICATION?

## Learning from unsuccessful applications

Not all applications for Listed Building Consent are successful. There are many reasons for refusal of Consent, and it is useful to be aware of these when considering your own application. Some cases and reasons for refusal are given below including the key concerns of the LPA:

Proposals and reasons for refusal	Example response
<b>1.</b> The visual impact of proposed 210 <b>photovoltaic panels</b> deemed harmful	<ul style="list-style-type: none"><li>• ‘...will have a detrimental impact on the setting of heritage assets including listed buildings, the Bath Conservation Area and the Bath World Heritage Site and also important and significant historic views of the city’</li><li>• ‘...will cause visual harm to the protected building and the setting of adjacent heritage assets’</li></ul>
Not enough detail has been provided on the possible impact of the building	<ul style="list-style-type: none"><li>• ‘...lack of information relating to the structural analysis of the...building and the impact on the roof and the integrity of the structure resulting from the installation <b>[of photovoltaic panels]</b>’</li><li>• ‘...lack of information relating to an analysis of the physical and structural impact on the roof structures...and therefore the proposals may lead to structural harm and damage to historic fabric’</li></ul>
Not enough detail has been provided on the history and listing of the building	<ul style="list-style-type: none"><li>• ‘...lack of information regarding...the heritage significance of the building and its context’</li></ul>
Lack of awareness of relevant planning policies	<ul style="list-style-type: none"><li>• ‘...the proposals are regarded as contrary to Planning (Listed Buildings &amp; Conservation Areas) Act 1990, Planning Policy 5: Planning for the Historic Environment and local and national policy guidance’</li></ul>

## WHAT MAKES A GOOD LISTED BUILDING APPLICATION?

Proposals and reasons for refusal	Example response
<b>2.</b> The visual impact of <b>internal wall insulation</b> regarded as unacceptable	<ul style="list-style-type: none"><li>• ‘...the wall insulation will result in the loss from view of important historic fabric including original lime plaster wall finishes and internal joinery.’</li><li>• ‘...the insulation will unacceptably alter the character of the interior of the building...’</li></ul>
Detrimental physical & technical impact of internal wall insulation	<ul style="list-style-type: none"><li>• ‘...Traditionally constructed historic buildings with a solid wall construction rely on the transfer-ence of moisture from within the wall so that it can be dissipated as vapour. Internally this process relies on adequate ventilation however it is clear that the aims of thermally upgrading the building are to minimise draughts and cold air entering the building.’</li><li>• ‘...likely to cause harm to internal fabric resulting from the inevitable increase in levels of damp and condensation...’</li><li>• ‘...likely that interstitial condensation between the existing internal wall surface and the internal surface of the wall insulation will occur.’</li><li>• ‘...although the aims of improving the thermal performance of historic buildings is supported in principle, this cannot be at the expense of heritage value and historic architectural interest and preservation.’</li><li>• ‘...there is a potential for physical harm to occur following the installation of the wall insulation...’</li></ul>

## WHAT MAKES A GOOD LISTED BUILDING APPLICATION?

Objections may also relate to the following, and may come from either the LPA or external commentators:

- Where the impact on a historic building or the setting of heritage assets has not been recognised or considered by the applicant or has been played down
- Where the application has not demonstrated an attempt to minimise the impact on a building's appearance (e.g. the use of discreet product design and styles)
- Where inadequate detail has been provided in general, e.g. lack of specification details, no heritage impact assessment/ statement
- Where plans and drawings are not of a professional standard, lack detail or are inaccurate
- Where a relatively high-impact measure (e.g. a solar panel) is proposed and other lower impact measures have not also been considered or applied.

## USEFUL RESOURCES AND INFORMATION

### **Bath & North East Somerset Council:**

To access our Sustainable Construction Checklist:

<https://beta.bathnes.gov.uk/policy-and-documents-library/sustainable-construction-checklist>

For information on Bath & North East Somerset Council's climate emergency declaration:

<https://www.bathnes.gov.uk/climate-emergency>

For all queries on planning, building control and listed buildings you can contact the Council via the Council Connect Service. All details can be found here:

<https://beta.bathnes.gov.uk/contact-us>

For Building control advice:

[www.bathnes.gov.uk/environmentandplanning](http://www.bathnes.gov.uk/environmentandplanning)

[www.bathnes.gov.uk/services/planning-and-building-control/listed-buildings/climate-change-and-historic-environment](http://www.bathnes.gov.uk/services/planning-and-building-control/listed-buildings/climate-change-and-historic-environment)

Planning consents information:

[Planning | Bath and North East Somerset Council \(bathnes.gov.uk\)](http://bathnes.gov.uk/planning)

[Apply for planning permission | Bath and North East Somerset Council \(bathnes.gov.uk\)](http://bathnes.gov.uk/apply-for-planning-permission)

### **Retrofitting and Sustainable Construction Guidance**

#### **Climate Change and Your Home**

Green & Low Carbon Construction Directory

[www.climatechangeandyourhome.org.uk](http://www.climatechangeandyourhome.org.uk)

#### **Energy Saving Trust**

Independent and impartial advice about energy and water saving solutions

<https://energysavingtrust.org.uk/>

## USEFUL RESOURCES AND INFORMATION

### **FutureBuild**

The world's biggest event for sustainable design, construction and the built environment

<https://www.futurebuild.co.uk/>

### **Green Register**

A register of sustainable construction professionals in the South West

<https://www.greenregister.org.uk/>

### **Low Impact Living Initiative**

Retrofitting Factsheets and information

<https://www.lowimpact.org/lowimpact-topic/0-retrofitting-intro/>

### **National Insulation Association**

Find an accredited insulation installer locally

<https://www.nia-uk.org/>

### **National Microgeneration Scheme**

National quality assurance certification scheme for microgeneration products and installation

<https://www.gov.uk/government/publications/microgeneration-certification-scheme-mcs-transfer-to-mcs-service-company>

### **Planning Portal**

UK Government's online planning regulation and building resource. Find out if you need planning permission or use the interactive house features – terrace and semi-detached – for advice on common householder projects including microgeneration.

<https://www.planningportal.co.uk/>

### **Sustainable Traditional Building Alliance**

Responsible retrofit of traditional buildings guide

[http://www.sdfoundation.org.uk/downloads/RESPONSIBLE-RETROFIT\\_FINAL\\_20\\_SEPT\\_2012.pdf](http://www.sdfoundation.org.uk/downloads/RESPONSIBLE-RETROFIT_FINAL_20_SEPT_2012.pdf)



## USEFUL RESOURCES AND INFORMATION

### **Transition Bath**

Bath based group increasing awareness of climate change and planning changes to deal take action at a local level.

<https://transitionbath.org/>

### **Warmer Bath**

Informative local guide to improving energy efficiency of traditional homes in the city of Bath

[www.cse.org.uk/downloads/file/warmer\\_bath\\_june2011.pdf](http://www.cse.org.uk/downloads/file/warmer_bath_june2011.pdf)

### **Wessex Water**

Free water saving packs and information about water saving in and around Bath.

<https://www.wessexwater.co.uk/>

### **Wood Burning Stoves and Boilers**

This B&NES webpage which helps residents choose the cleanest possible fuel for their home and offers advice on wood burning and open fires: [Open Fires, Wood Burning and Air Quality](#)

[Energy Saving Trust: Biomass - wood-fuelled stoves with back boilers](#)

### **Zero Carbon Hub**

Information on challenges, issues and opportunities related to developing, building and marketing your low and zero carbon homes.

<https://zerocarbonhub.org/>

## USEFUL RESOURCES AND INFORMATION

### Useful Resources and Information

#### Heritage Organisations & Amenity Societies:

##### Historic England

<https://historicengland.org.uk/>

##### Historic Scotland

[www.historic-scotland.gov.uk/](http://www.historic-scotland.gov.uk/)

##### The Sustainable Traditional Buildings Alliance

[www.spab.org.uk/](http://www.spab.org.uk/)

##### Bath Preservation Trust

[www.bath-preservation-trust.org.uk/](http://www.bath-preservation-trust.org.uk/)

##### The Institute of Historic Building Conservation

[www.ihbc.org.uk/](http://www.ihbc.org.uk/)

##### Ancient Monuments Society

[www.ancientmonumentsociety.org.uk/](http://www.ancientmonumentsociety.org.uk/)

##### The Georgian Group

[www.georgiangroup.org.uk/docs/home/index.php](http://www.georgiangroup.org.uk/docs/home/index.php)

##### The Victorian Society

[www.victoriansociety.org.uk/](http://www.victoriansociety.org.uk/)

##### The Twentieth Century Society

[www.c20society.org.uk/](http://www.c20society.org.uk/)

## USEFUL RESOURCES AND INFORMATION

### Registers & Directories:

#### Building Conservation

A building conservation directory of services and professionals

[www.buildingconservation.com](http://www.buildingconservation.com)

#### Conservation Register

Find professionally qualified conservator-restorers in the UK and Ireland

[www.conservationregister.com](http://www.conservationregister.com)

#### Royal Institute of Chartered Surveyors (RICS)

Find an accredited Surveyor

[www.rics.org](http://www.rics.org) (follow the links to Services/Find a surveyor/Accreditation)

#### Royal Institute of British Architects (RIBA)

Find an Architect

[www.architecture.com/TheRIBA/TheRIBA.aspx](http://www.architecture.com/TheRIBA/TheRIBA.aspx)

#### Institute of Historic Building Conservation

HESPR: Historic Environment Service Provider Recognition

[www.ihbc.org.uk/hespr/](http://www.ihbc.org.uk/hespr/)

# GLOSSARY

## **Retrofitting**

Installation of energy efficiency measures in existing buildings

## **Energy Efficiency**

Reduction in consumption of energy for heat and power

## **Sustainable construction**

Building with positive Environmental impact

## **Green Infrastructure**

Strategically planned network of green spaces and other environmental features

## **Natural Stack Ventilation**

Cool fresh air drawn in from openings at lower levels of a building by opening a ventilation outlet at a higher level e.g. a window or ventilation hatch

## **Biomass/Biofuel**

Plant derived fuel that is a renewable energy source

## **Skimming**

Plastered sloped underside of a roof

## **Breathable**

Materials and building fabric that allows moisture permeability

## **SUDS (Sustainable Urban Drainage)**

Techniques to reduce adverse impacts of surface water drainage.

## **Cold Bridge**

Occurs when there is a thermal break in the insulating materials between the inside and outside of a building e.g. a gap in the wall or roof insulation, allowing heat to escape

## **Heating and hot water:**

**Efficient controls** – installing a thermostat, thermostatic radiator valves and a timer will help to make heating systems work in the most efficient way and will reduce fuel bills

## GLOSSARY

**Underfloor heating** – in some cases, underfloor heating can be a suitable alternative to conventional radiators. The system uses a low operating temperature that can be linked in with alternative heating sources that output at the same low temperature, for example solar panels

**PV's, solar thermal, biomass** – by installing renewable energy systems to heat hot water and provide space heating, less fossil fuel is used and therefore less CO<sub>2</sub> is emitted than conventional systems such as electric heating

### **Windows:**

**Frames** – there are several choices of materials for window frames such as plastic, timber and aluminium. Timber window frames are the best choice from an environmental point of view, but the timber should be sourced from well managed forests

**Glazing details** – heat loss through window glass is much greater than through walls and roofs. Insulating double or triple glazed units are now easy to source

and the glazing unit is filled with an inert gas, making it even more energy efficient

**Solar shading** – adding blinds, shutters and/or solar shades on the outside of the windows can keep unwanted sun out in the summertime and will help to keep indoor temperatures at a comfortable level

**Thermal bridging** – it is important to make sure that the gap between the window frame and the wall is well sealed otherwise heat will be lost around the window even if the window itself is very energy efficient

### **Interior Design:**

**Lighting** – LED lighting (and to a lesser extent, compact fluorescent lights) use a fraction of the energy of normal light bulbs but give the same light output and there are a range of options to choose from. Although initially more expensive to buy, they last for many times longer than conventional bulbs and the costs are easily recouped over time Natural daylight is even cheaper.

## GLOSSARY

**Painting** – synthetic paints contain hundreds of chemicals in them and can cause health problems when used. There are a number of alternative 'natural' paints and finishes available that are better for the environment and better for the occupants

**Flooring** – there are many natural flooring alternatives to conventional synthetic choices (nylon carpet, pvc vinyl flooring and laminate as examples) that have a lower impact on the environment, are more durable and in many cases are healthier alternatives such as linoleum, wool carpet, and solid timber flooring.

### **Roof:**

**Insulation** – as much as 20% of energy bills can be saved by good loft insulation (200mm minimum) which is easy and inexpensive to install

**Room in a roof** – where appropriate, creating a room in the roof (the attic space) rather than building out to the side or back of a house can be less expensive and saves on materials. Even if the room is not in the original plans for the attic, making sure the roof is not

filled with trussed rafters allows a room in the roof to be created at a future date.

**Materials** – using natural slate or clay tiles as opposed to concrete tiles or asphalt means less energy is used to make the building materials in the first place thereby reducing fossil fuel use

**Solar panels** – providing the roof faces south (or south east/west) and is unshaded there will be an opportunity to generate heat for hot water and/or electricity from solar panels. The roof structure needs to be designed so that it is strong enough to take the extra weight of the panels

### **Ventilation:**

**Airtightness** – lots of heat is lost through unintentional gaps in the walls, floors and roofs of buildings creating draughts and so it is extremely important to make sure these are eliminated. This down to good detailing and good site workmanship

## GLOSSARY

**Natural and mechanical ventilation** – fresh air is an important aspect of a healthy building and can be provided by natural ventilation systems rather than mechanical which use energy to operate

**Heat recovery** – if mechanical ventilation systems are used, a heat recovery system can really help to capture and reuse the 'waste' heat from outgoing air

**Indoor Air Quality (IAQ)** – it is important to provide adequate fresh air into a building to maintain a healthy indoor environment and to remove pollutants such as smoke, cooking odours and offgassing from building materials. When a building is very airtight it is even more important that fresh air is regularly introduced to a building through either natural or mechanical means

**Moisture control** – moisture build-up in a building – due to cooking, breathing and washing – can cause mould growth resulting in an unhealthy indoor environment. Trickle vents in windows, mechanical extract and careful use of opening windows can expel the moisture and keep levels down to a minimum

### **Walls:**

**Insulation** – up to half the heat can be lost through uninsulated walls so it is essential that adequate insulation – in the cavity, internal or external depending on the wall construction – is installed. This will reduce fuel bills and make the building more comfortable to occupy

**Thermal mass** – using heavyweight materials such as brick, block and concrete can moderate the temperatures inside buildings by holding onto the heat during the day and releasing again at night-time when it is needed

**Materials** – using natural materials such as brick and timber cladding means less energy is used to make the building materials in the first place saving on fossil fuel use



## GLOSSARY

### **Water:**

**Reduce consumption** – the best way to save water is to reduce it at the point of use so installing low flush, dual flush WC's, low flow shower heads and tap aerators will help save water and reduce water bills

**Rainwater harvesting** – collecting rainwater and using it for washing machines, garden irrigation and to flush WC's reduces the use of mains water (which is cleaned using fossil fuel energy) and reduces water bills

**Surface water run-off** – if rainwater that falls onto a property is kept on site it can help to reduce the burden on mains drainage during heavy rainfall and allow topping up of the local water table. Using porous paving, swales and retention ponds will all help to keep rainwater on site

### **Floors:**

**Insulation** – a significant amount of heat can be lost through uninsulated floors, so it is essential that adequate insulation – below or above the slab or between

joists depending on the floor construction – is installed. This will reduce fuel bills and make the building more comfortable to occupy

**Thermal mass** – using heavyweight materials such as concrete or floor finishes such as tiles or stone can moderate the temperatures inside buildings by holding onto the heat during the day and releasing again at night-time when it is needed

**Materials** – using natural floor finishes such as stone, timber and linoleum means less energy is used to make the building materials in the first place and saves on fossil fuel use.

